

Telmec

RADIO FREQUENCY FILTERING SYSTEMS

SINCE 1975 - MADE IN ITALY



AUTOMATIC FILTERS

BAND PASS - COMBINERS



MANUAL FILTERS

BAND PASS - BAND REJECT - NOTCH - COMBINERS

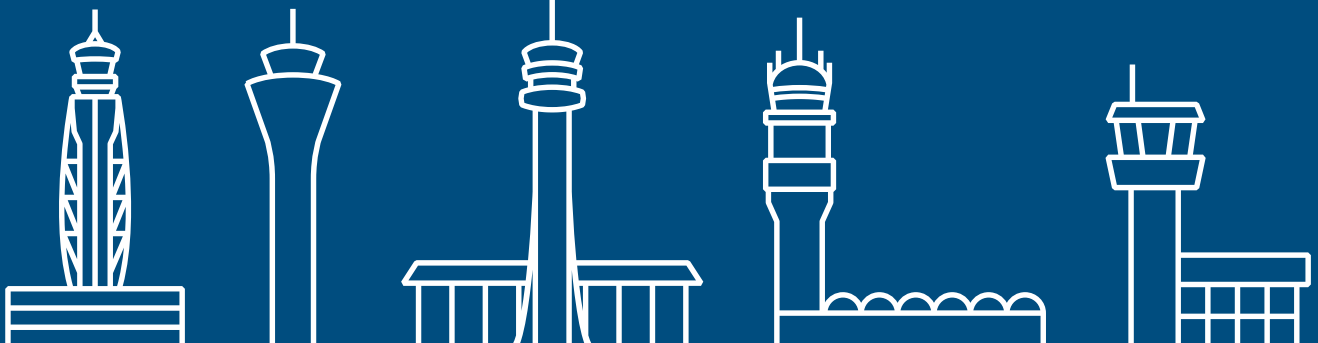
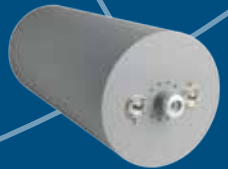
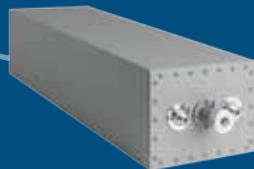

ATC CATALOGUE 2024

Telmec

RADIO FREQUENCY FILTERING SYSTEMS

SINCE 1975 - MADE IN ITALY

COMPANY PROFILE

TELMEC was founded in Florence in 1975 by Gino Borghesi as a company operating in the high precision mechanical and electromechanical sector.

Its main mission since then has been the design of filtering and combining products for radio signals in the different communication sites.

The company was taken over by its employees in 2006. TELMEC therefore develops and manufactures autonomously systems and components in the radio frequency field which are needed to operate an interference free service from frequency crowded radio sites. Our know how is the result of a forty year long research and development activity in the field of Ground to Air Radio Communications in the civilian market of the components used.



TELMEC is certified according to the ISO 9001:2008 Quality Control standard.



TELMEC focus is on some specific areas of activity:

- Development of the most cost effective radio frequency system solution based on customer's requirements;
- Achievement of optimum electrical performance and thermal stability through a careful material selection and thoughtful construction;
- Standard high quality production of filters, combiners, couplers for the radio site. We constantly make use of customer's feedback from the field to improve our quality level;
- Utilization of state of art electronics for the control of the automatic tuning of the filters;
- Capability of developing customized solutions;
- Punctual delivery of products which are tuned in factory according to the configuration supplied by the customer.

The strength of our organization is therefore based on the quality of our products and our constant support to the customer. The quality concept comes easy to our company as our high standards for the manufacturing process must include stringent control of the dimensions and surface finish of the components used.







SUMMARY

BAND PASS FILTERS – VHF

080 rectangular cavity	<u>10</u>
085 rectangular cavity	<u>11</u>
120 rectangular cavity	<u>12</u>
165 rectangular cavity	<u>13</u>
165 rectangular cavity non telescopic	<u>14</u>
180 rectangular cavity	<u>15</u>
210 square cavity	<u>16</u>
210 double cavity window coupled	<u>17</u>
280 rectangular cavity	<u>18</u>
100 round cavity	<u>19</u>
200 round cavity	<u>20</u>
300 round cavity	<u>21</u>

BAND PASS FILTERS - UHF

080 rectangular cavity	<u>24</u>
120 rectangular cavity	<u>25</u>
165 rectangular cavity	<u>26</u>
165 rectangular cavity non telescopic	<u>27</u>
180 rectangular cavity	<u>28</u>
210 square cavity	<u>29</u>
210 double cavity window coupled	<u>30</u>
280 rectangular cavity	<u>31</u>
100 round cavity	<u>32</u>

BAND REJECT FILTERS – NOTCH FILTERS

Band Reject – 210 square cavity	<u>36</u>
Notch – 100 round cavity hybrid coupled	<u>37</u>
Notch – 100 round cavity	<u>38</u>
Notch – 210 square cavity	<u>40</u>
Notch – 180 rectangular cavity	<u>41</u>

COMBINERS - VHF

STAR – 080 double cavity	<u>44</u>
STAR – 100 single cavity	<u>45</u>
STAR – 120 single cavity	<u>46</u>
STAR – 120 double cavity	<u>47</u>
STAR - 165 single cavity	<u>48</u>
STAR - 165 double cavity	<u>49</u>
STAR – 180 single cavity	<u>50</u>
STAR – 180 double cavity	<u>51</u>
STAR – 200 single cavity	<u>52</u>
STAR – 210 single cavity	<u>54</u>
STAR – 210 double cavity	<u>55</u>
MANIFOLD – 210 double cavity	<u>56</u>
DOUBLE BRIDGE – 180 cavity	<u>57</u>
DOUBLE BRIDGE – 180 cavity – High selectivity	<u>58</u>
DOUBLE BRIDGE – 280 cavity	<u>59</u>

COMBINERS - UHF

STAR – 100 round cavity	<u>62</u>
STAR – 120 single cavity	<u>63</u>
STAR – 210 single cavity	<u>64</u>
STAR – 210 double cavity	<u>65</u>
DOUBLE BRIDGE – 120 cavity	<u>66</u>
DOUBLE BRIDGE – 120 cavity – high selectivity	<u>67</u>
DOUBLE BRIDGE - 280 cavity	<u>68</u>

AUTOMATIC TUNING BAND PASS FILTERS - VHF

085 double cavity window coupled	<u>72</u>
210 single cavity	<u>73</u>
210 double cavity window coupled	<u>74</u>

AUTOMATIC TUNING BAND PASS FILTERS - UHF

210 single cavity	<u>78</u>
210 double cavity window coupled	<u>79</u>

AUTOMATIC TUNING COMBINERS - VHF

STAR 210 double cavity	<u>82</u>
------------------------	-----------



BAND
PASS
FILTERS
VHF

Band Pass Filters VHF

080 rectangular cavity

Double cavity window coupled band pass filter in the 112-157 VHF range can be allocated in one half 2 unit 19" cabinet. Frequency tuning and window coupling are manually regulated through mechanical knobs. The adjustable window allows for different selectivity settings.



Electrical Specifications

Frequency band:	112 - 157 MHz
Impedance:	50 Ω
Max Power:	100W CW
Insertion loss:	Adjustable, window coupling, rotating loops

Mechanical Specifications

Connector Type:	N Female
Dimensions:	½ 19" rack, 2HU, depth 675 mm
Operating temp.:	-10°C to +55°C
Tuning method:	Rotary knobs, telescopic movement

Band Pass Filters	Channels	Cabinet 2HU	Attenuation
FPB080-V/2 F02ER080M1WDxxxx	1	½	20dB \pm 0.4% from f_0 36 dB \pm 1% from f_0

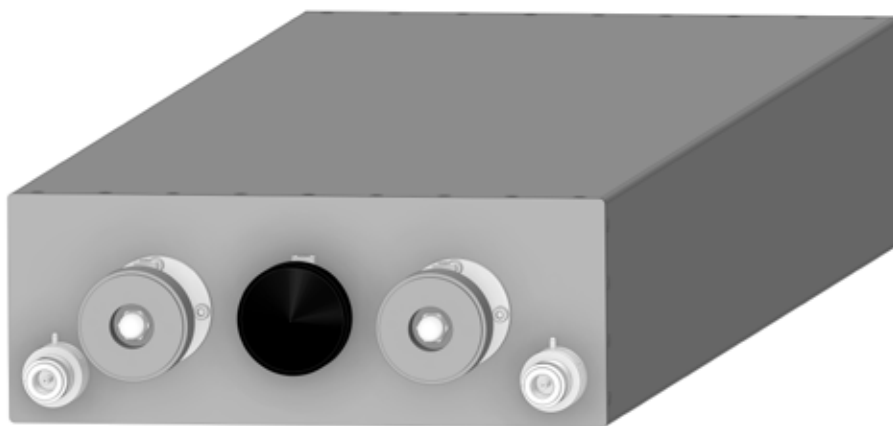

FPB080-V/2

Band Pass Filters VHF

085 rectangular cavity

Double cavity window coupled band pass filter the VHF range can be allocated in one half 2 unit 19" cabinet. Frequency tuning is manually regulated through mechanical knobs.

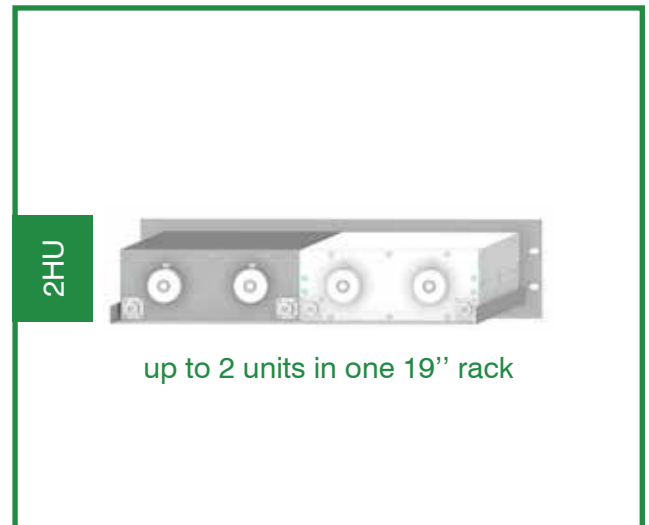

Electrical Specifications

Frequency band:	112 - 156 MHz
Impedance:	50 Ω
Max Power:	50W CW
Insertion loss:	2 dB

Mechanical Specifications

Connector Type:	N Female
Dimensions:	1/2 19" rack, 2HU, depth 560 mm
Operating temp.:	-10°C to +55°C
Tuning method:	Rotary knobs, telescopic movement

Band Pass Filters	Channels	Cabinet 2HU	Attenuation
FPB085-V/2 F02ER085M1WDxxxx	1	1/2	20dB \pm 0.4% from f_0 35 dB \pm 1% from f_0

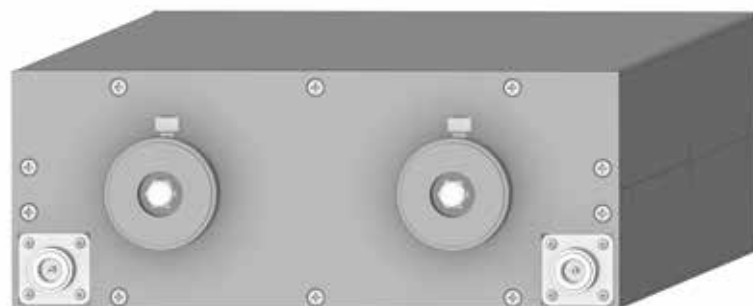

FPB085-V/2

Band Pass Filters VHF

120 rectangular cavity

Single or double cavity band pass filters up to 4 channels in the VHF range can be allocated in one 3 unit 19" cabinet. Frequency tuning and insertion loss can be regulated through adjustable loops and mechanical knobs.

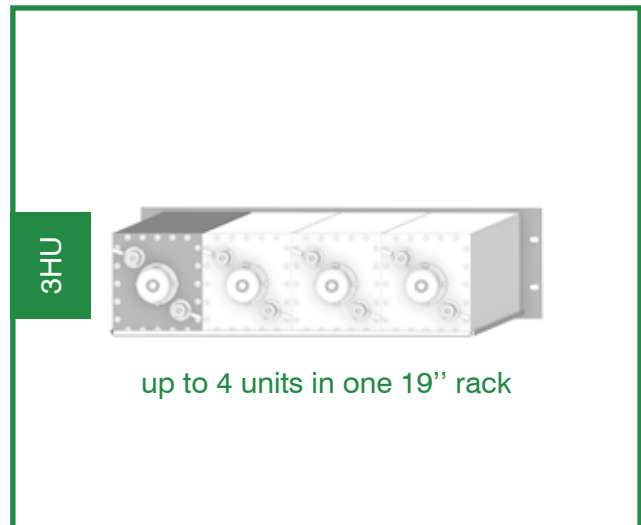

Electrical Specifications

Frequency band:	112 - 156 MHz
Impedance:	50 Ω
Max Power:	100W CW
Insertion loss:	Adjustable, rotating loops

Mechanical Specifications

Connector Type:	N Female
Dimensions:	19" rack, 3HU, depth 728 mm
Operating temp.:	-10°C to +55°C
Tuning method:	Rotary knobs, telescopic movement

Band Pass Filters	Channels	Cabinet 3HU	Attenuation
FPB120-V/1 F02ER120M10Sxxxx	1	1	11dB ± 500 kHz 1dB I.L. at 127.5 MHz
FPB120-V/1-1 (double cavity) F02ER120M1CDxxxx	1	1	25dB ± 500 kHz 2dB I.L. at 127.5 MHz
FPB120-V/2 F02ER120M20Sxxxx	2	1	11dB ± 500 kHz 1dB I.L. at 127.5 MHz
FPB120-V/3 F02ER120M30Sxxxx	3	1	11dB ± 500 kHz 1dB I.L. at 127.5 MHz
FPB120-V/4 F02ER120M40Sxxxx	4	1	11dB ± 500 kHz 1dB I.L. at 127.5 MHz
FPB120-V/1-1-1 (triple cavity) F02ER120M1WTxxxx	1	1	50dB ± 1 MHz 2dB I.L. at 118-137 MHz

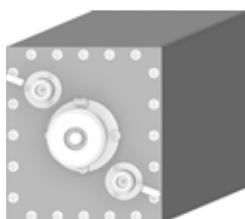

AST-1034
F05ER120M10Sxxxx



FPB120-V/1

Band Pass Filters VHF

165 rectangular cavity

Single, up to 2 channels, or double cavity band pass filters in the VHF range can be allocated in one 4 unit 19" cabinet. Frequency tuning and insertion loss can be regulated through adjustable loops and mechanical knobs.

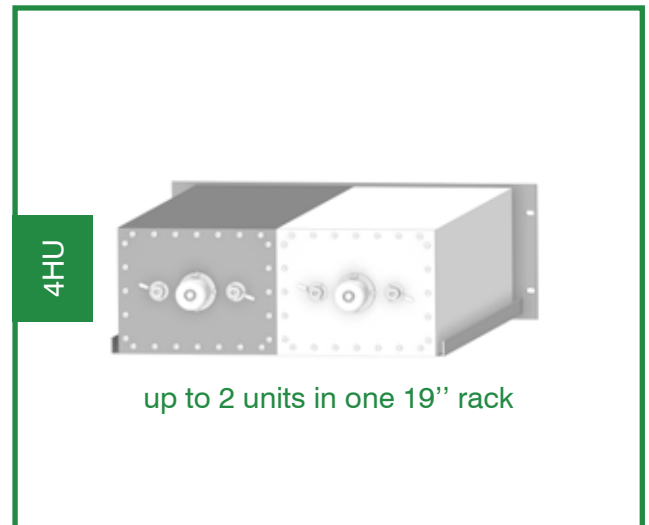

Electrical Specifications

Frequency band:	118 - 156 MHz
Impedance:	50 Ω
Max Power:	100W CW
Insertion loss:	Adjustable, rotating loops

Mechanical Specifications

Connector Type:	N Female
Dimensions:	19" rack, 4HU, depth 670 mm
Operating temp.:	-10°C to +55°C
Tuning method:	Rotary knob, telescopic movement loops

Band Pass Filters	Channels	Cabinet 4HU	Attenuation
FPB165-V/1 F02VR165M10Sxxxx	1	1	15dB \pm 500 kHz 1dB I.L. at 127.5 MHz
FPB165-V/1-1 (double cavity) F02VR165M1CDxxxx	1	1	30dB \pm 500 kHz 2dB I.L. at 127.5 MHz
FPB165-V/1D F02VR165M20Sxxxx	2	1	15dB \pm 500 kHz 1dB I.L. at 127.5 MHz

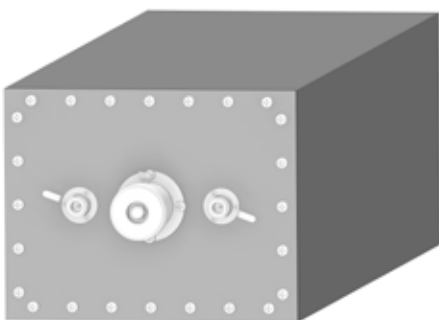

AST-1360
F05VR165M10Sxxxx

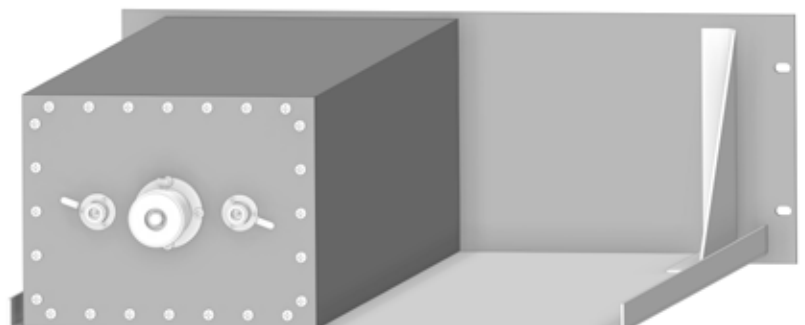

FPB165-V/1

Band Pass Filters VHF

165 rectangular cavity non telescopic

This filter has the same electrical performance of the telescopic version, with adjustable insertion loss and mechanical knob for frequency tuning. Furthermore, this is a cost effective solution, but overall depth depends on actual tuned frequency.



Electrical Specifications

Frequency band:	118 - 156 MHz
Impedance:	50 Ω
Max Power:	100W CW
Insertion loss:	Adjustable, rotating loops

Mechanical Specifications

Connector Type:	N Female
Dimensions:	19" rack, 4HU, depth 600 mm (max)
Operating temp.:	-10°C to +55°C
Tuning method:	Rotary knob, non telescopic movement

Band Pass Filters	Channels	Cabinet 4HU	Attenuation
FPB165-V/1NT F02VR165M10Sxxxx	1	1	13 dB @ $f_0 \pm 0.5\%$ I.L. 1 dB
FPB165-V/1DNT F02VR165M20Sxxxx	2	1	13 dB @ $f_0 \pm 0.5\%$ I.L. 1 dB

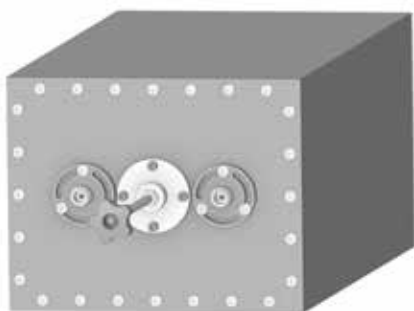

AST-1886
F05VR165M1Sxxxx

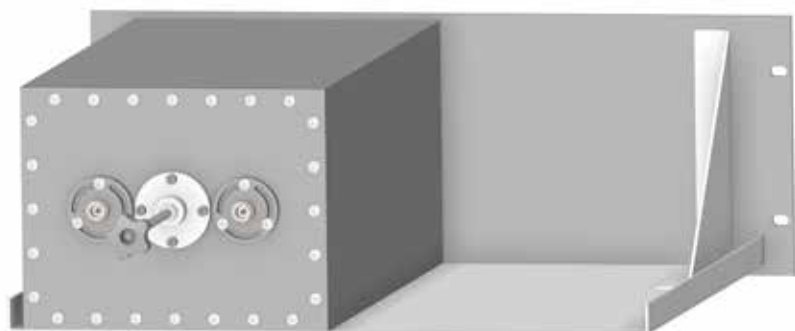

FPB165-V/1NT

Band Pass Filters VHF

180 rectangular cavity

Single, up to 2 channels, or double cavity band pass filters in the VHF range can be allocated in one 4 unit 19" cabinet. Frequency tuning and insertion loss can be regulated through adjustable loops and mechanical knobs.

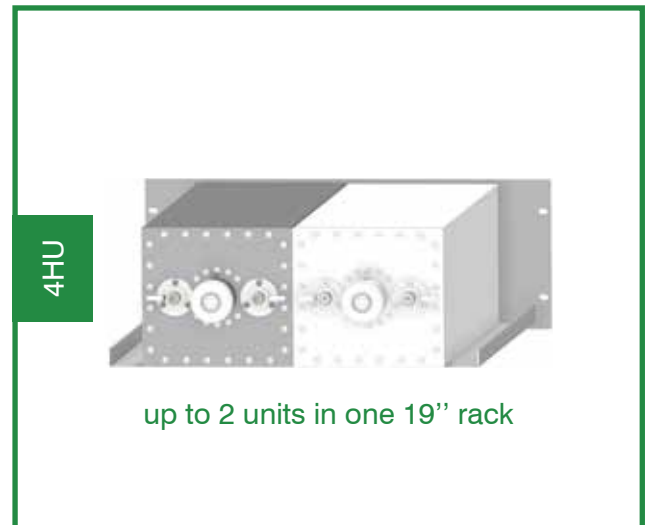

Electrical Specifications

Frequency band:	118 - 156 MHz
Impedance:	50 Ω
Max Power:	200W CW
Insertion loss:	Adjustable, rotating loops

Mechanical Specifications

Connector Type:	N Female
Dimensions:	19" rack, 4HU, depth 670 mm
Operating temp.:	-10°C to +55°C
Tuning method:	Rotary knobs, telescopic movement

Band Pass Filters	Channels	Cabinet 4HU	Attenuation
FPB180-V/1 F02VR180M10Sxxxx	1	1	13dB \pm 500 kHz 1dB I.L. at 127.5 MHz
FPB180-V/1-1 (double cavity) F02VR180M1CDxxxx	1	1	28dB \pm 500 kHz 2dB I.L. at 127.5 MHz
FPB180-V/1D F02VR180M20Sxxxx	2	1	13dB \pm 500 kHz 1dB I.L. at 127.5 MHz

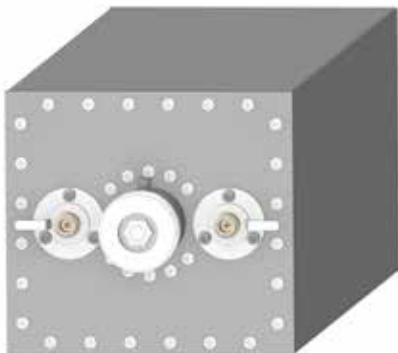

AST-1023
F05VR180M10Sxxxx

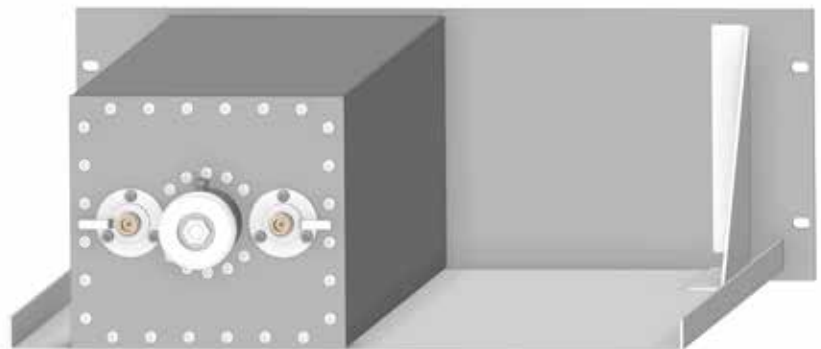

FPB180-V/1

Band Pass Filters VHF

210 square cavity

Single, up to 2 channels, or double cavity band pass filters up to 2 channels in the VHF range can be allocated in one 5 unit 19" cabinet. Frequency tuning and insertion loss can be regulated through adjustable loops and mechanical knobs.

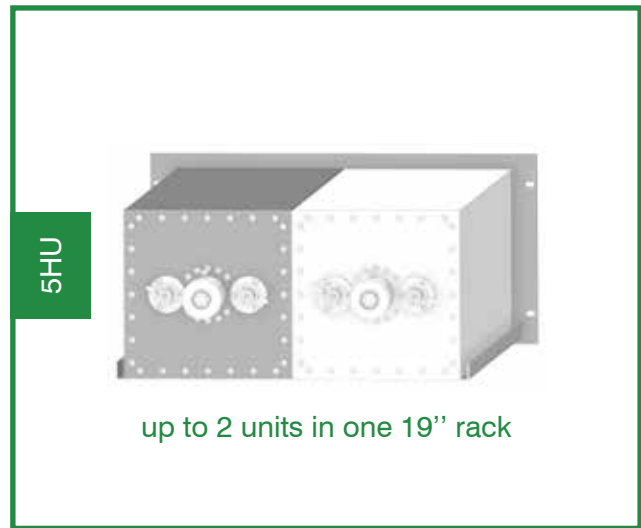

Electrical Specifications

Frequency band:	118 - 156 MHz
Impedance:	50 Ω
Max Power:	200W CW
Insertion loss:	Adjustable, rotating loops

Mechanical Specifications

Connector Type:	N Female
Dimensions:	19" rack, 5HU, depth 670 mm
Operating temp.:	-10°C to +55°C
Tuning method:	Rotary knob, telescopic movement

Band Pass Filters	Channels	Cabinet 5HU	Attenuation
FPB210-V/1 F02VS210M10Sxxxx	1	1	15dB \pm 500 kHz 1dB I.L. at 127.5 MHz
FPB210-V/1-1 (double cavity) F02VS210M1CDxxxx	1	1	32dB \pm 500 kHz 2dB I.L. at 127.5 MHz
FPB210-V/1D F02VS210M20Sxxxx	2	1	15dB \pm 500 kHz 1dB I.L. at 127.5 MHz

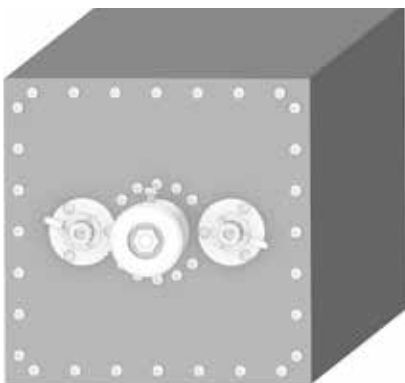

AST-0610
F05VS210M10SXXXX

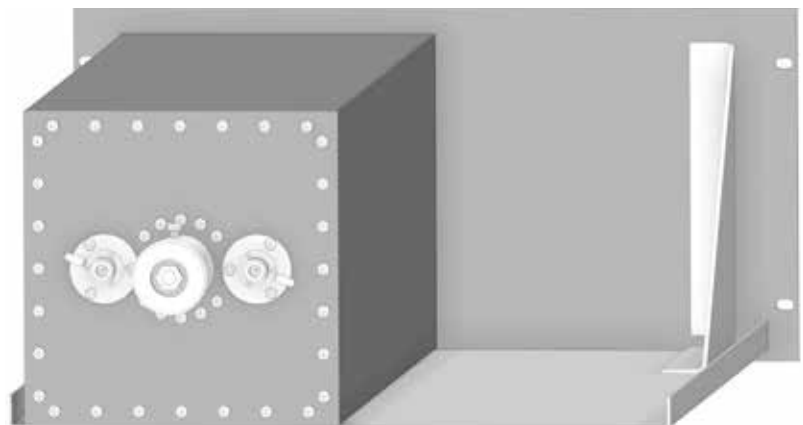

FPB210-V/1

Band Pass Filters VHF

210 cavity window coupled

Double cavity band pass filter in the VHF range can be allocated in one 5 unit 19" cabinet. Frequency tuning and insertion loss can be regulated through rotating loops and mechanical knobs. The window coupling is adjusted through a rotating central knob.

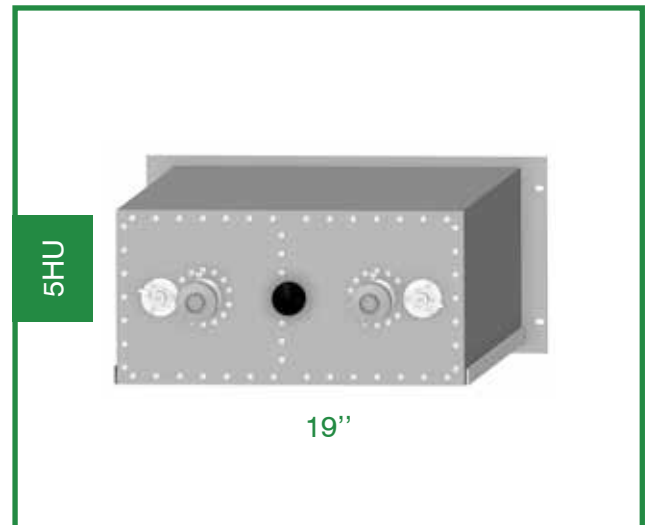

Electrical Specifications

Frequency band:	118 - 156 MHz
Impedance:	50 Ω
Max Power:	200W CW
Insertion loss:	Adjustable window coupling, rotating loops.

Mechanical Specifications

Connector Type:	N Female
Dimensions:	19" rack, 5HU, depth 670 mm
Operating temp.:	-10°C to +55°C
Tuning method:	Rotary knobs, telescopic movement

Band Pass Filters	Channels	Cabinet 5HU	Attenuation
FPB210-V/2 F02VS210M1WDxxxx	1	1	15dB \pm 500 kHz 1dB I.L. at 127.5 MHz

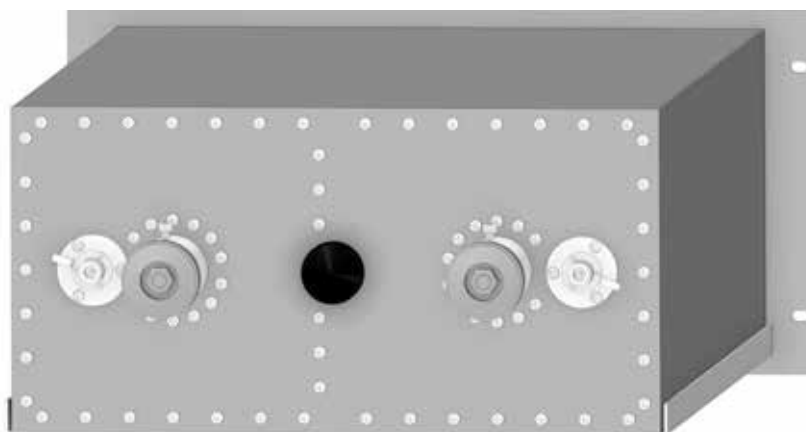

FPB210-V/2

Band Pass Filters VHF

280 rectangular cavity

Single cavity band pass filter - single channel in the VHF range can be allocated in one 5 unit 19" cabinet. Frequency tuning and insertion loss can be regulated through adjustable loops and mechanical knob

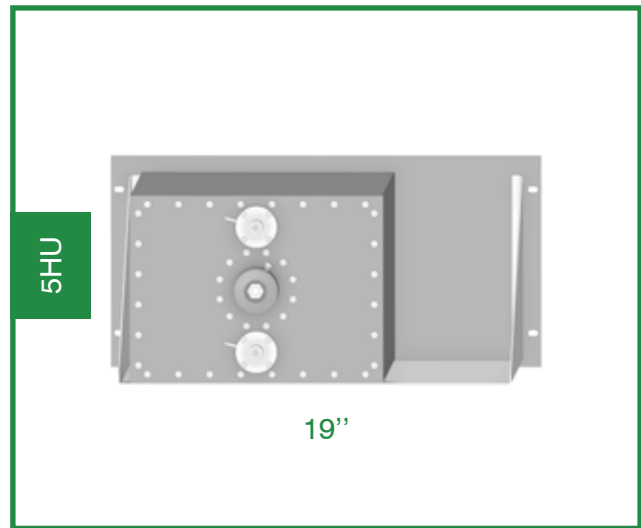

Electrical Specifications

Frequency band:	118 - 156 MHz
Impedance:	50 Ω
Max Power:	200W CW
Insertion loss:	Adjustable, rotating loops

Mechanical Specifications

Connector Type:	N Female
Dimensions:	19" rack, 5HU, depth 700 mm
Operating temp.:	-10°C to +55°C
Tuning method:	Rotary knob, telescopic movement

Band Pass Filters	Channels	Cabinet 5HU	Attenuation
FPB280-V/1 F02VR280M10Sxxxx	1	1	19 dB @ f0 +/- 500 kHz

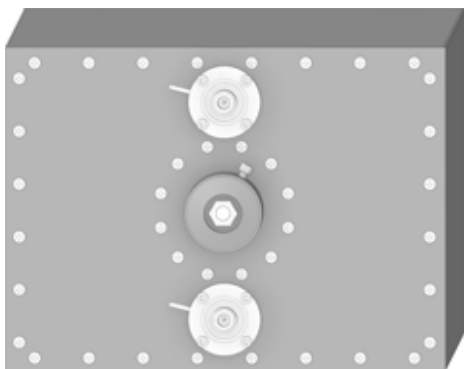

AST-1003
F05VR280M10Sxxxx

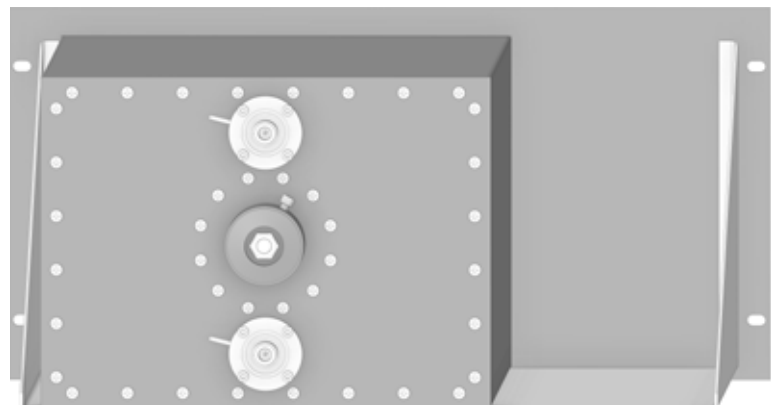

FPB280-V/1

Band Pass Filters VHF

100 round cavity

Single or double cavity filters are implemented using 100 round cavities in the VHF range. Optimum performance is achieved through a rugged construction.



Electrical Specifications

Frequency band:	118 - 137 MHz
Impedance:	50 Ω
Max Power:	100W CW
Insertion loss:	Adjustable window coupling, rotating loops.

Mechanical Specifications

Connector Type:	N Female
Dimensions:	19" rack, 4HU, depth 620 mm
Operating temp.:	-10°C to +55°C
Tuning method:	Rotary knob, non telescopic

Band Pass Filters	Attenuation	Thermal Stability (ppm°C)	Input Power (CW)
FPB100-V/1 F02LC100M10Sxxxx	12dB ±0.75%Fo 1dB I.L.	3	100W
FPB100-V/1-1 F02LC100M1CDxxxx	12dB ±0.75%Fo 1dB I.L.	3	100W
FPB100-V/2 F02LC100M20Sxxxx	24dB ±0.75%Fo 2dB I.L.	3	100W



AST-0108
F05LC100M10Sxxxx

FPB100-V/1

FPB100-V/2

Band Pass Filters VHF

200 round cavity

Single or double cavity filters are implemented using 200 round cavities in the VHF range. Optimum performance is achieved through a rugged construction.



Electrical Specifications

Frequency band:	118 - 137 MHz
Impedance:	50 Ω
Max Power:	200W CW
Insertion loss:	Adjustable window coupling, rotating loops.

Mechanical Specifications

Connector Type:	N Female
Dimensions:	19" rack, 5HU, depth 625 mm
Operating temp.:	-10°C to +55°C
Tuning method:	Rotary knob, non telescopic movement

Band Pass Filters	Attenuation	Thermal Stability (ppm°C)	Input Power (CW)
FPB200-V/1 F02LC200M10Sxxxx	15dB ±500 KHz 1dB I.L.	3	200W
FPB200-V/1-1 F02LC200M1CDxxxx	15dB ±500 KHz 1dB I.L.	3	200W
FPB200-V/2 F02LC200M20Sxxxx	30dB±500 KHz 2dB I.L.	3	200W

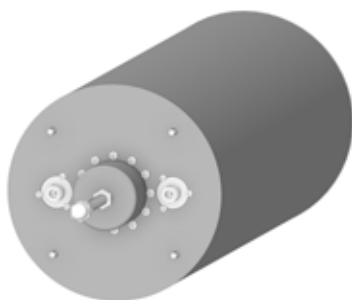

AST-0152
F05LC200M10Sxxxx

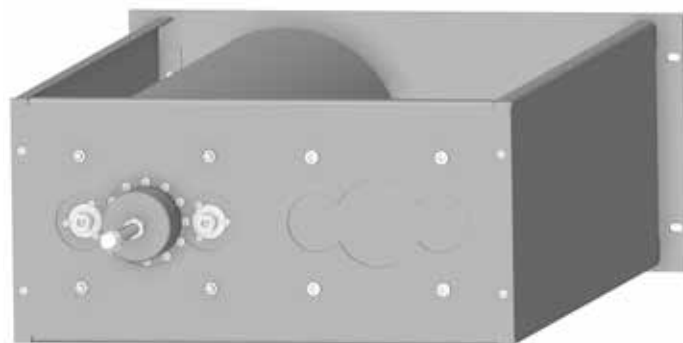

FPB200-V/1

Band Pass Filters VHF

300 round cavity

Single cavity filters are implemented using 300 round cavities in the VHF range. Optimum performance is achieved through a rugged construction.



Electrical Specifications

Frequency band:	118 - 156 MHz
Impedance:	50 Ω
Max Power:	200W CW
Insertion loss:	Adjustable window coupling, rotating loops.

Mechanical Specifications

Connector Type:	N Female
Dimensions:	19" rack, 7HU, depth 735 mm
Operating temp.:	-10°C to +55°C
Tuning method:	Rotary knob, telescopic movement

Model	Attenuation	Thermal Stability (ppm°C)	Input Power (CW)
AST-1621 F05VC300M10Sxxxx	15dB \pm 200 KHz 1.5dB I.L	3.5	200W

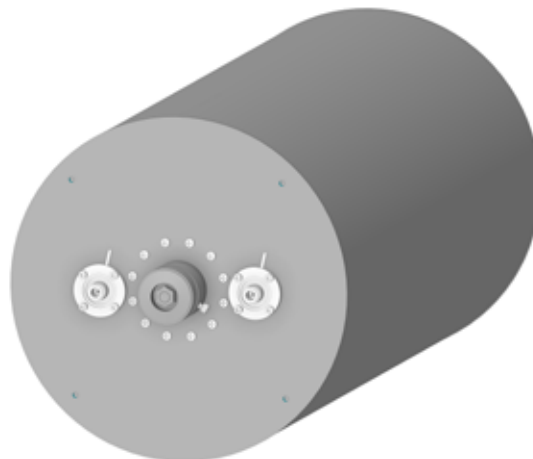

AST-1621

BAND
PASS
FILTERS
UHF

Band Pass Filters UHF

080 rectangular cavity

Double cavity window coupled band pass filter in the 225-400 MHz UHF range can be allocated in one half 2 unit 19" cabinet. Frequency tuning and insertion loss can be regulated through rotating loops and mechanical knobs. The window coupling is adjusted through a rotating central knob.

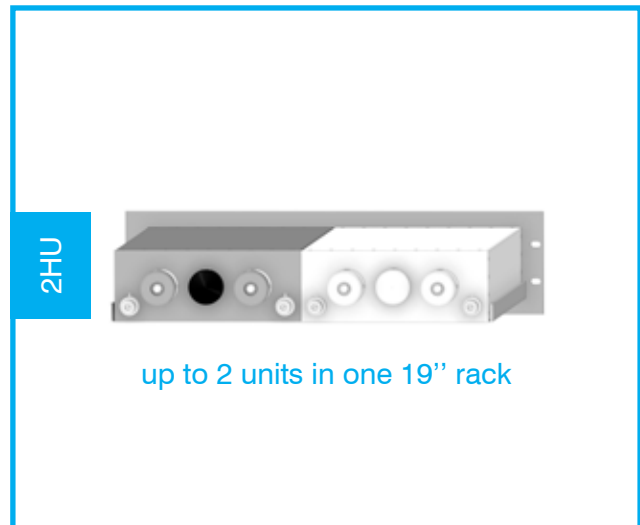

Electrical Specifications

Frequency band:	225 - 400 MHz
Impedance:	50 Ω
Max Power:	100W CW
Insertion loss:	adjustable rotating loops - window coupling

Mechanical Specifications

Connector Type:	N Female
Dimensions:	1/2 19" rack, 2HU, depth 535 mm
Operating temp.:	-10°C to +55°C
Tuning method:	Rotary knobs, telescopic movement

Band Pass Filters	Channels	Cabinet 2HU	Attenuation
FPB080-U/2 F02UR080M1WDxxxx	1	1/2	25dB \pm 0.4% from f_0 40 dB \pm 1% from f_0



FPB080-U/2

Band Pass Filters UHF

120 rectangular cavity

Single cavity band pass filters up to 4 channels in the UHF range can be allocated in one 3 unit 19" cabinet. Frequency tuning and insertion loss can be regulated through adjustable loops and mechanical knobs.

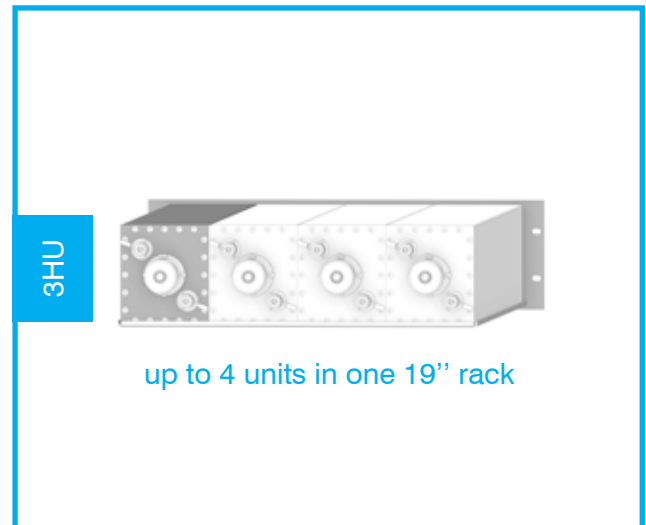

Electrical Specifications

Frequency band:	225 - 400 MHz
Impedance:	50 Ω
Max Power:	100W CW
Insertion loss:	Adjustable, rotating loops

Mechanical Specifications

Connector Type:	N Female or 7/16
Dimensions:	19" rack, 3HU, depth 560 mm
Operating temp.:	-10°C to +55°C
Tuning method:	Rotary knob, telescopic movement

Band Pass Filters	Channels	Cabinet 3HU	Attenuation
FPB120-U/1 F02UR120M10Sxxxx	1	1	13dB \pm 0.4% 1dB I.L. at 312 MHz
FPB120-U/2 F02UR120M20Sxxxx	2	1	13dB \pm 0.4% 1dB I.L. at 312 MHz
FPB120-U/3 F02UR120M30Sxxxx	3	1	13dB \pm 0.4% 1dB I.L. at 312 MHz
FPB120-U/4 F02UR120M40Sxxxx	4	1	13dB \pm 0.4% 1dB I.L. at 312 MHz

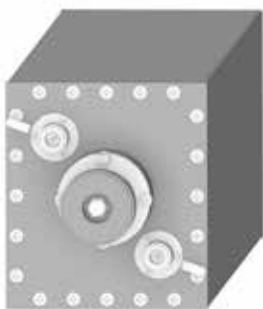

AST-1052
F05UR120M10Sxxxx

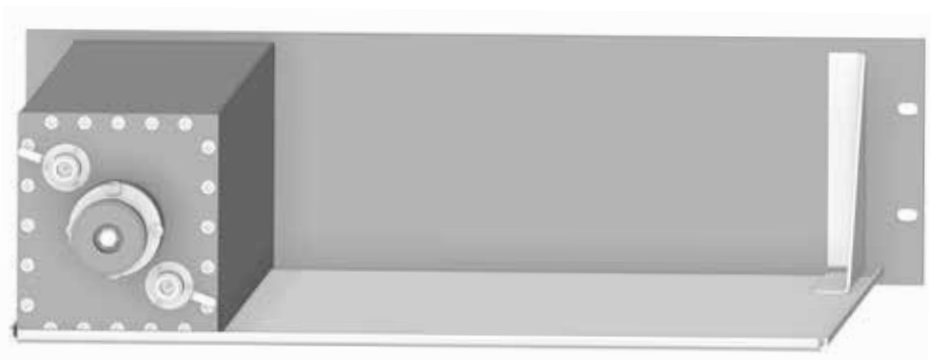

FPB120-U/1

Band Pass Filters UHF

165 rectangular cavity

Single cavity band pass filters up to 2 channels in the UHF range can be allocated in one 4 unit 19" cabinet. Frequency tuning and insertion loss can be regulated through adjustable loops and mechanical knobs.

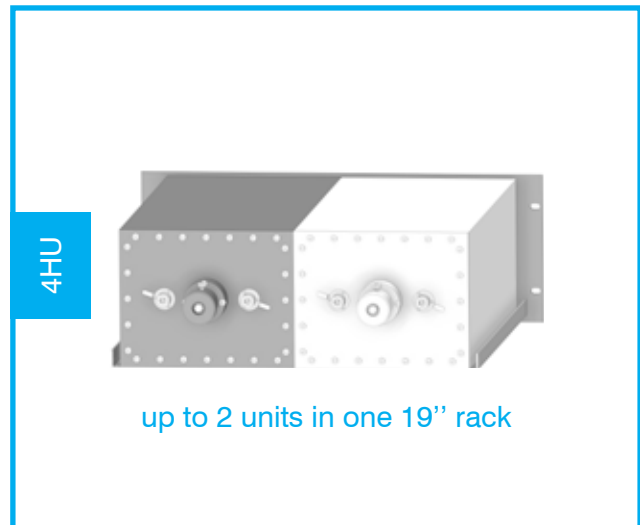

Electrical Specifications

Frequency band:	225 - 400 MHz
Impedance:	50 Ω
Max Power:	100W CW
Insertion loss:	Adjustable, rotating loops

Mechanical Specifications

Connector Type:	N Female
Dimensions:	19" rack, 4HU, depth 560 mm
Operating temp.:	-10°C to +55°C
Tuning method:	Rotary knob, telescopic movement

Band Pass Filters	Channels	Cabinet 4HU	Attenuation
FPB165-U/1 F02UR165M10Sxxxx	1	1	16dB ± 0.4% 1dB I.L. @ 312 MHz
FPB165-U/1D F02UR165M20Sxxxx	2	1	16dB ± 0.4% 1dB I.L. @ 312 MHz

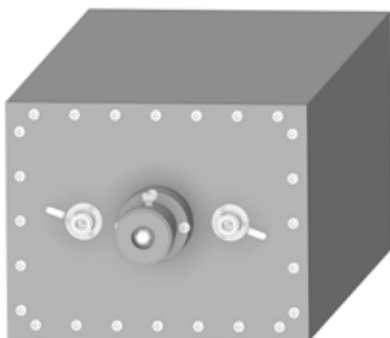

AST-1754
F05UR165M10Sxxxx

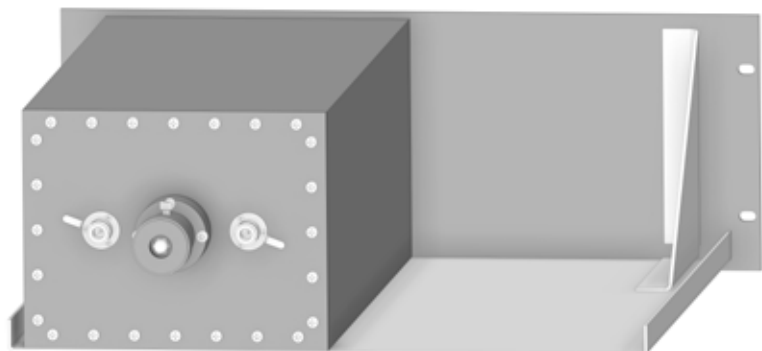

FPB165-U/1

Band Pass Filters UHF

165 rectangular cavity non telescopic

This filter has the same electrical performance of the telescopic solution, with adjustable insertion loss and mechanical knob for frequency tuning. Furthermore, this is a cost effective solution, but overall depth depends on actual tuned frequency.

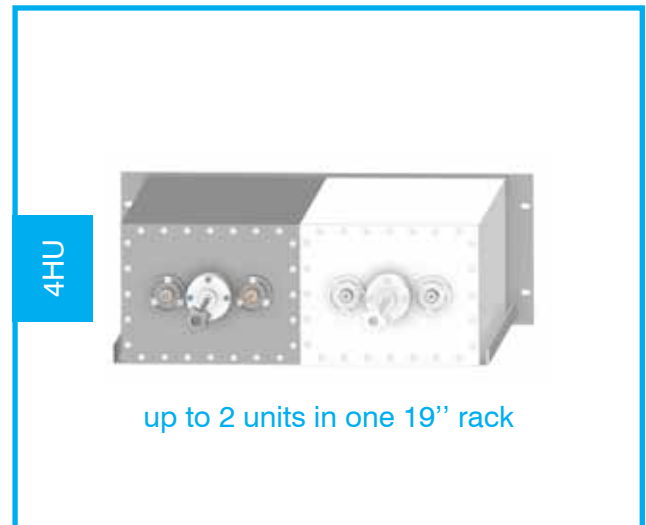

Electrical Specifications

Frequency band:	225 - 400 MHz
Impedance:	50 Ω
Max Power:	100W CW
Insertion loss:	Adjustable, rotating loops

Mechanical Specifications

Connector Type:	N Female
Dimensions:	19" rack, 4HU, depth 660mm (max)
Operating temp.:	-10°C to +55°C
Tuning method:	Rotary knob, non telescopic movement

Band Pass Filters	Channels	Cabinet 4HU	Attenuation
FPB165-U/1NT F02UR165M10Sxxxx	1	1	16dB @ $f_0 \pm 0.5\%$
FPB165-U/1DNT F02UR165M20Sxxxx	2	1	16dB @ $f_0 \pm 0.5\%$

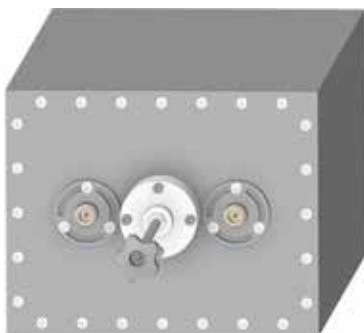

AST-1887
F05UR165M10Sxxxx

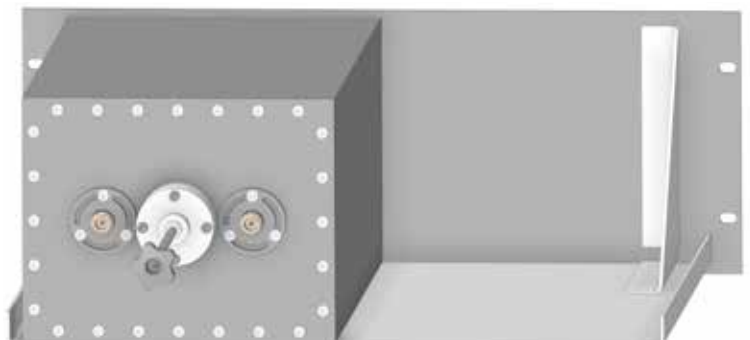

FPB165-U/1NT

Band Pass Filters UHF

180 rectangular cavity

Single cavity band pass filters up to 2 channels in the UHF range can be allocated in one 4 unit 19" cabinet. Frequency tuning and insertion loss can be regulated through adjustable loops and mechanical knobs.

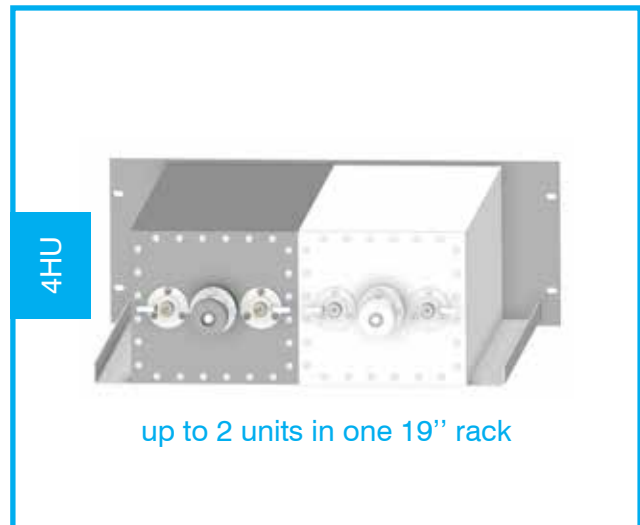

Electrical Specifications

Frequency band:	225 - 400 MHz
Impedance:	50 Ω
Max Power:	200W CW
Insertion loss:	Adjustable, rotating loops

Mechanical Specifications

Connector Type:	N Female
Dimensions:	19" rack, 4HU, depth 560 mm
Operating temp.:	-10°C to +55°C
Tuning method:	Rotary knob, telescopic movement

Band Pass Filters	Channels	Cabinet 4HU	Attenuation
FPB180-U/1 F02UR180M10Sxxxx	1	1	16dB \pm 0.4% 1dB I.L. @312 MHz
FPB180-U/1D F02UR180M20Sxxxx	2	1	16dB \pm 0.4% 1dB I.L. @312 MHz

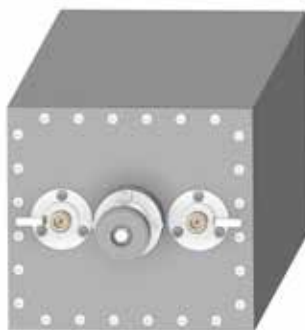

AST-1753
F05UR180M10Sxxxx

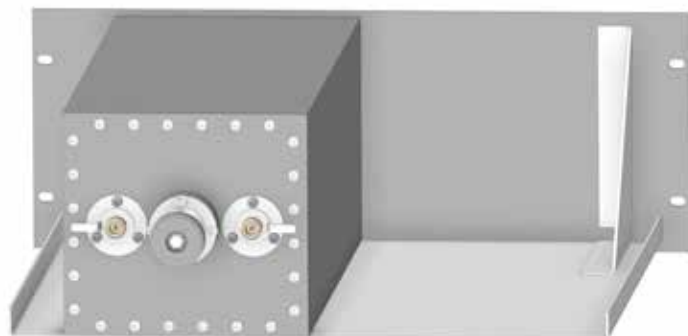

FPB180-U/1

Band Pass Filters UHF

210 rectangular cavity

Single cavity band pass filters up to 2 channels in the UHF range can be allocated in one 5 unit 19" cabinet. Frequency tuning and insertion loss can be regulated through rotating loops and mechanical knobs.

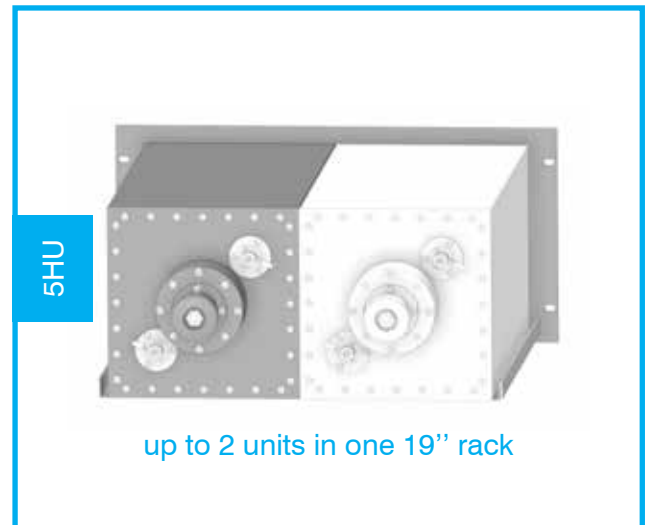

Electrical Specifications

Frequency band:	225 - 400 MHz
Impedance:	50 Ω
Max Power:	200W CW
Insertion loss:	Adjustable, rotating loops

Mechanical Specifications

Connector Type:	N Female
Dimensions:	19" rack, 5HU, depth 600 mm
Operating temp.:	-10°C to +55°C
Tuning method:	Rotary knob, telescopic movement

Band Pass Filters	Channels	Cabinet 5HU	Attenuation
FPB210-U/1 F02US210M10Sxxxx	1	1	17dB \pm 0.4% 1dB I.L. @312 MHz
FPB210-U/1D F02US210M20Sxxxx	2	1	17dB \pm 0.4% 1dB I.L. @312 MHz

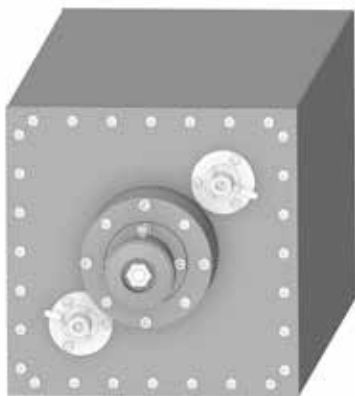

AST-1193
F05US210M10Sxxxx

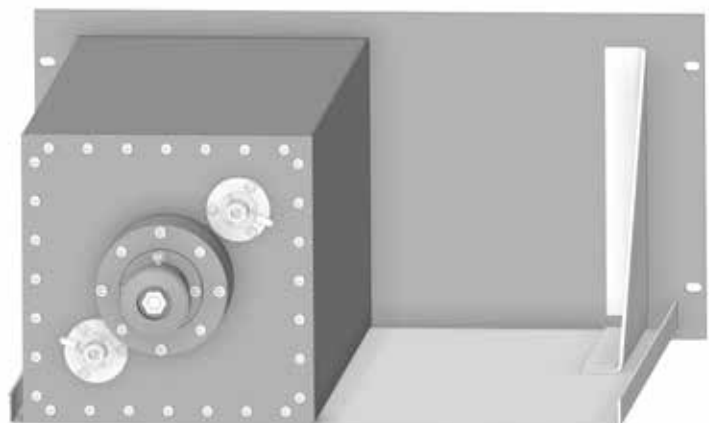

FPB210-U/1

Band Pass Filters UHF

210 double cavity window coupled

Double cavity band pass filters single channel in the UHF range can be allocated in one 5 unit 19" cabinet. Frequency tuning and insertion loss can be regulated through adjustable loops and mechanical knobs.

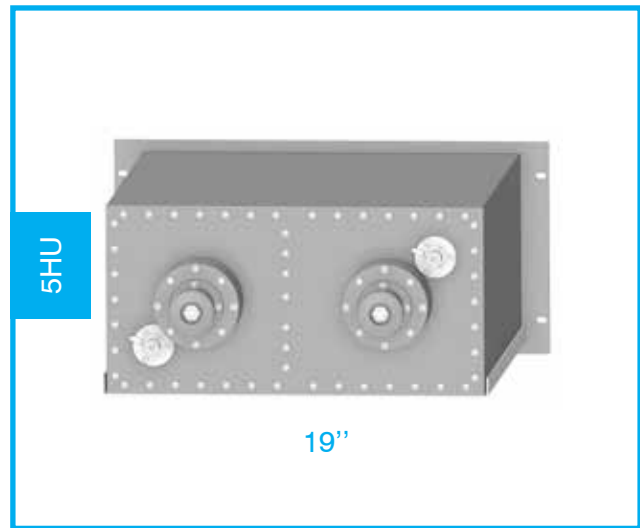

Electrical Specifications

Frequency band:	225 - 400 MHz
Impedance:	50 Ω
Max Power:	200W CW
Insertion loss:	Adjustable, rotating loops

Mechanical Specifications

Connector Type:	N Female
Dimensions:	19" rack, 5HU, depth 600 mm
Operating temp.:	-10°C to +55°C
Tuning method:	Rotary knob, telescopic movement

Band Pass Filters	Channels	Cabinet 5HU	Attenuation
FPB210-U/2 F02US210M1WDxxxx	1	1	32dB \pm 0.4% from f_0

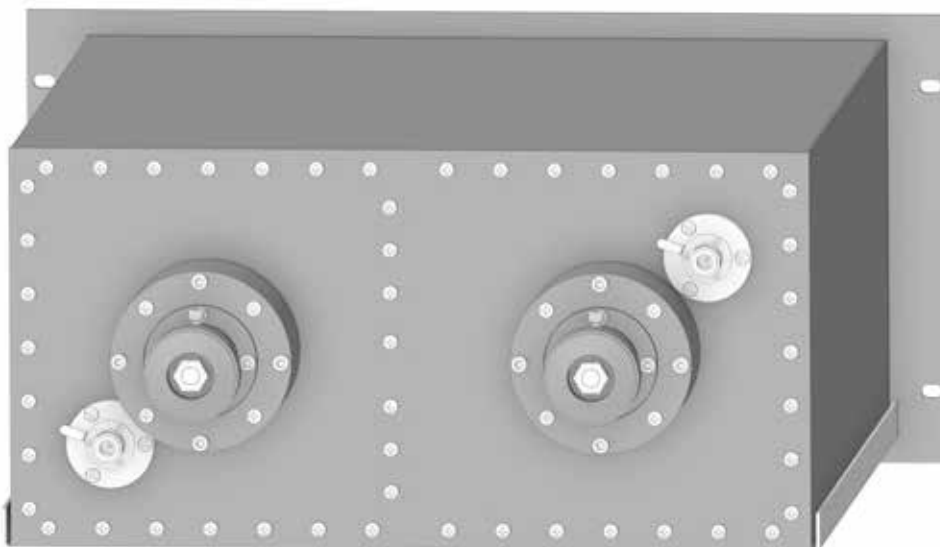

FPB210-U/2

Band Pass Filters UHF

280 rectangular cavity

Single cavity band pass filter - single channel in the UHF range can be allocated in one 5 unit 19" cabinet. Frequency tuning and insertion loss can be regulated through adjustable loops and mechanical knob

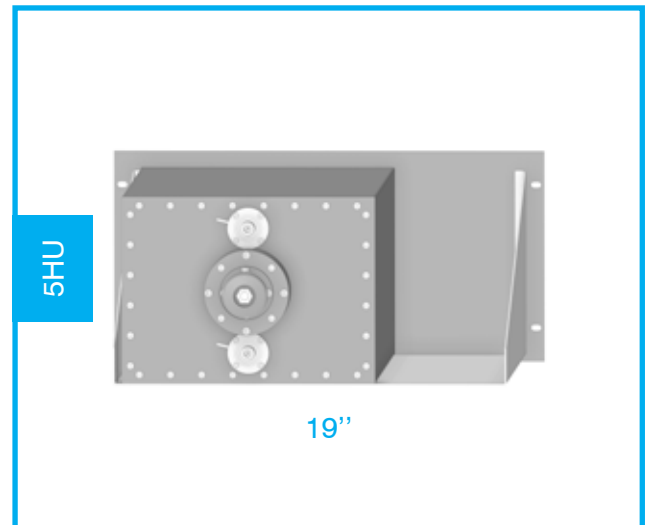

Electrical Specifications

Frequency band:	225 - 400 MHz
Impedance:	50 Ω
Max Power:	200W CW
Insertion loss:	Adjustable, rotating loops

Mechanical Specifications

Connector Type:	N Female
Dimensions:	19" rack, 5HU, depth 600 mm
Operating temp.:	-10°C to +55°C
Tuning method:	Rotary knob, telescopic movement

Band Pass Filters	Channels	Cabinet 5HU	Attenuation
FPB280-U/1 F02UR280M10Sxxxx	1	1	14dB \pm 500kHz 1dB I.L. @312 MHz

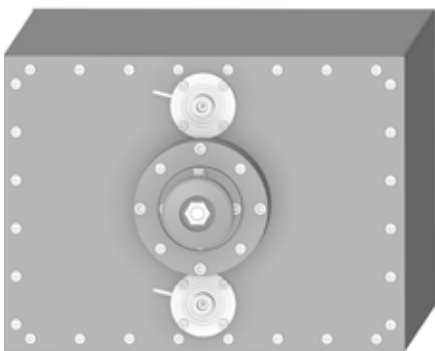

AST-1111
F05UR280M10Sxxxx

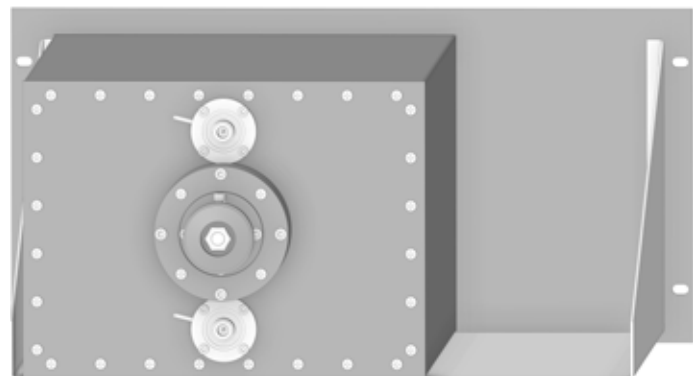

FPB280-U/1

Band Pass Filters UHF

100 round cavity

Single cavity filters and combiners are implemented using 100 mm round cavities in the 225 – 400 MHz UHF range.

Optimum performance is achieved through a rugged construction.



Electrical Specifications

Frequency band:	225 - 400 MHz
Impedance:	50 Ω
Max Power:	100W CW
Insertion loss:	Adjustable, rotating loops

Mechanical Specifications

Connector Type:	N Female
Dimensions:	19" rack, 4HU, depth 620 mm
Operating temp.:	-10°C to +55°C
Tuning method:	Rotary knob, telescopic movement

Model	Attenuation	Thermal Stability (ppm°C)	Input Power (CW)
FPB100-U/1 F02UC100M10Sxxxx	12dB \pm 0.75%Fo 1dB I.L.	5	100W
FPB100-U/1-1 F02UC100M20Sxxxx	12dB \pm 0.75%Fo 1dB I.L.	5	100W
FPB100-U/2 F02UC100M1CDxxxx	24dB \pm 0.75%Fo 2dB I.L.	5	100W

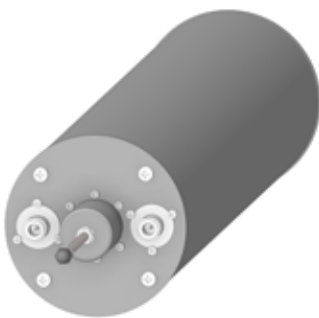

AST-0149
F05UC100M10SXXXX



FPB100-U/1

BAND
REJECT
FILTERS
—
NOTCH
FILTERS

Band Reject Filter VHF

210 square cavity

One or two band reject filters in the VHF range can be allocated in one 5 unit 19" cabinet. Frequency tuning and attenuation can be regulated through adjustable mechanical knobs.

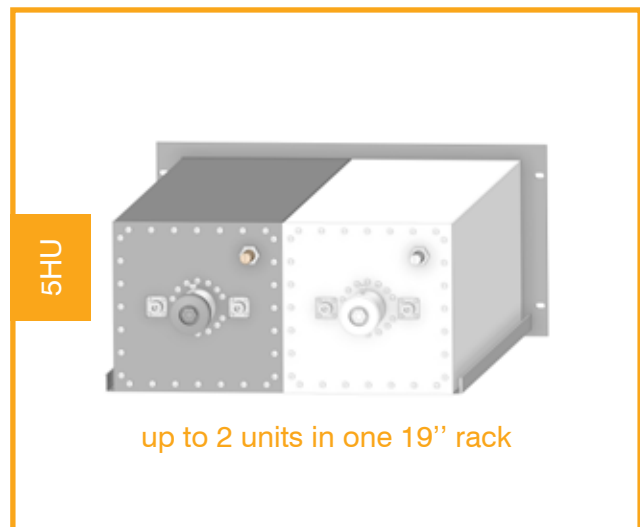

Electrical Specifications

Frequency band:	118 - 144 MHz
Impedance:	50 Ω
Max Power:	100W CW
Insertion loss:	≤ 1.5 dB

Mechanical Specifications

Connector Type:	N Female
Dimensions:	19" rack, 5HU, depth 670 mm
Operating temp.:	-10°C to +55°C
Tuning method:	Rotary knob, telescopic movement

Band Reject Filters	Channels	Cabinet 5HU	Attenuation (each single cavity)
FPB210-V/1BR F03VS210M10Sxxxx	1	1	> 22 dB, @ +200kHz or -200kHz notch > 40 dB, @ +500kHz or -500kHz notch
FPB210-V/1-1BR F03VS210M20Sxxxx	2	1	> 22 dB, @ +200kHz or -200kHz notch > 40 dB, @ +500kHz or -500kHz notch

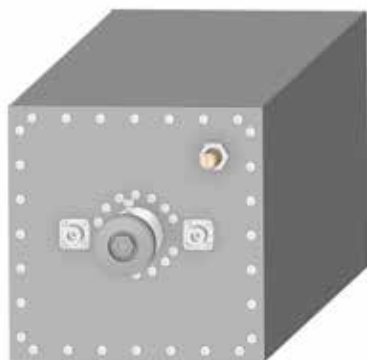

AST-0610BR
F05VS210M10Sxxxx

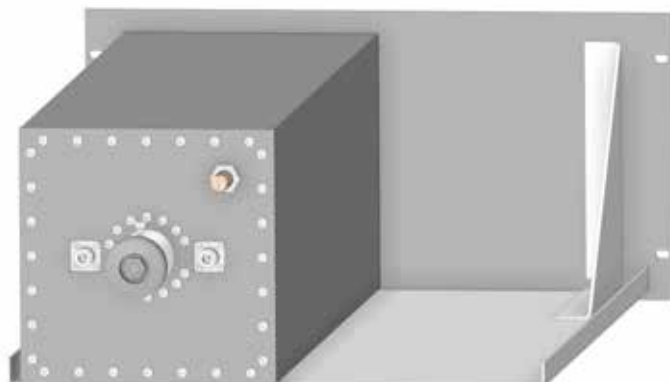

FPB210-V/1BR

Notch Filters VHF

100 round cavity hybrid coupled

The Notch filter unit is composed of two round 100 cavities in a 4HU 19" cabinet. Frequency tuning and attenuation can be regulated through adjustable mechanical knobs.

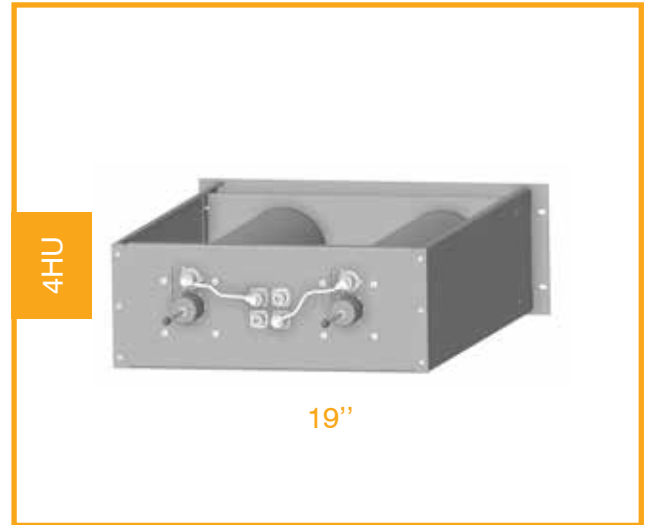

Electrical Specifications

Frequency band:	118 - 137 MHz
Impedance:	50 Ω
Max Power:	100W CW
Insertion loss:	From 1 to 3 dB

Mechanical Specifications

Connector Type:	N Female
Dimensions:	19" rack, 4HU, depth 684 mm
Operating temp.:	-10°C to +55°C
Tuning method:	Rotary knob, non telescopic movement

Notch Filter	Channels	Cabinet 4HU	Attenuation
MCP100-V/2TLI F04SC120M1HSxxxx	1	1	> 35 dB, @ +200kHz or more notch
MCP100-V/2THI F04SC120M1HSxxxx	1	1	> 35 dB, @ +200kHz or more notch

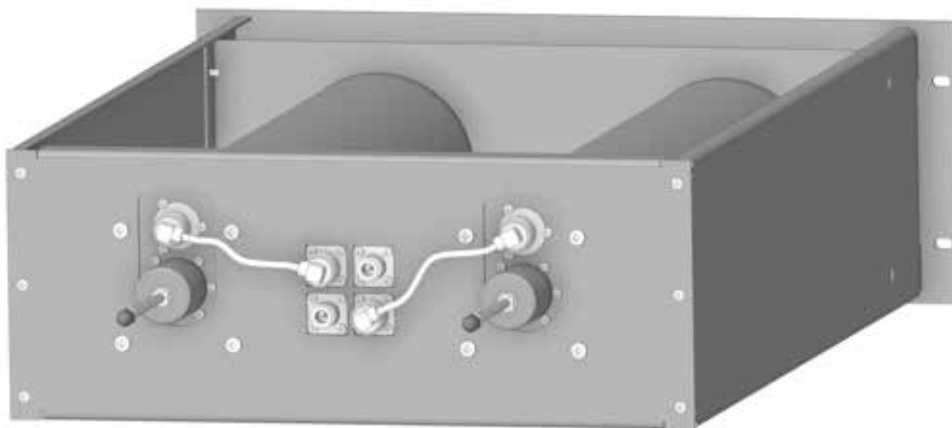

MCP100-V/2TLI
MCP100-V/2THI

Notch Filters VHF

100 round cavity - low pass

The Notch filter unit is composed of two round 100 cavities in a 4HU 19" cabinet. Frequency tuning and attenuation can be regulated through adjustable mechanical knobs.

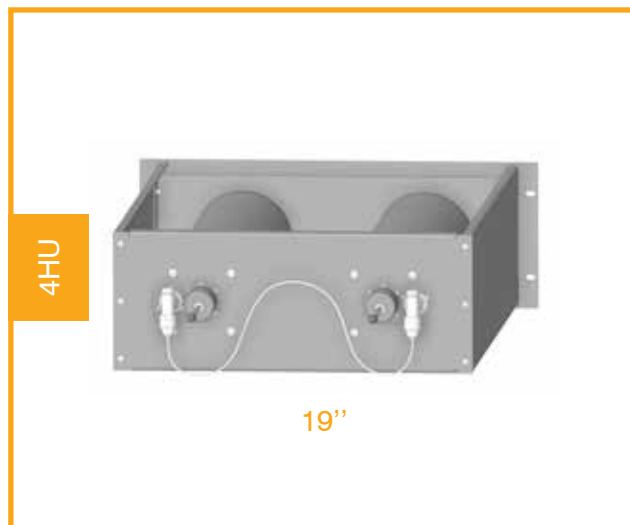

Electrical Specifications

Frequency band:	118 - 137 MHz
Impedance:	50 Ω
Max Power:	100W CW
Insertion loss:	From 1 to 3 dB

Mechanical Specifications

Connector Type:	N Female
Dimensions:	19" rack, 4HU, depth 620 mm
Operating temp.:	-10°C to +55°C
Tuning method:	Rotary knob, tuning rod

VHF Notch Filter	Channels	Cabinet 4HU	Attenuation
MCP100-V/2TL F04SC120M1CSxxxx	1	1	> 35 dB, @ -150kHz or more notch



MCP100-V/2TL

Notch Filters VHF

100 round cavity - high pass

The Notch filter unit is composed of two round 100 cavities in a 4HU 19" cabinet. Frequency tuning and attenuation can be regulated through adjustable mechanical knobs.

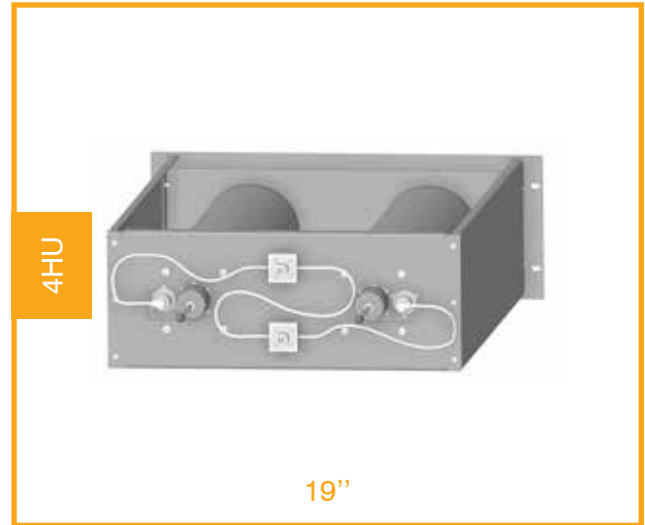

Electrical Specifications

Frequency band:	118 - 137 MHz
Impedance:	50 Ω
Max Power:	100W CW
Insertion loss:	From 1 to 3 dB

Mechanical Specifications

Connector Type:	N Female
Dimensions:	19" rack, 4HU, depth 620 mm
Operating temp.:	-10°C to +55°C
Tuning method:	Rotary knob, tuning rod

VHF Notch Filter	Channels	Cabinet 4HU	Attenuation
MCP100-V/2TH F04SC120M1CSxxxx	1	1	> 35 dB, @ -150kHz or more notch

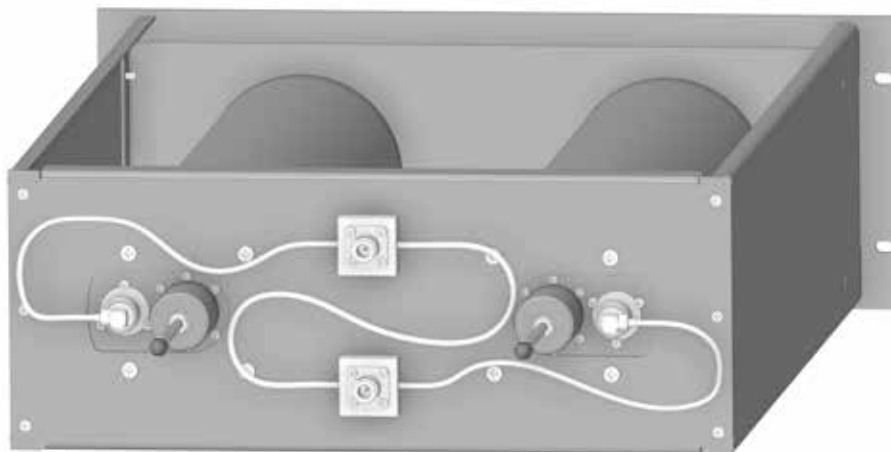

MCP100-V/2TH

Notch Filters VHF

210 square cavity

The Notch Filter is used when high attenuation is required for narrow spacing between the working and the rejected frequency in the VHF range. Attenuation and Insertion Loss can be adjusted by the rotating loops of the cavity. It is used for frequency spacing of 300 kHz or less. It is installed in a single 5 unit 19" cabinet.

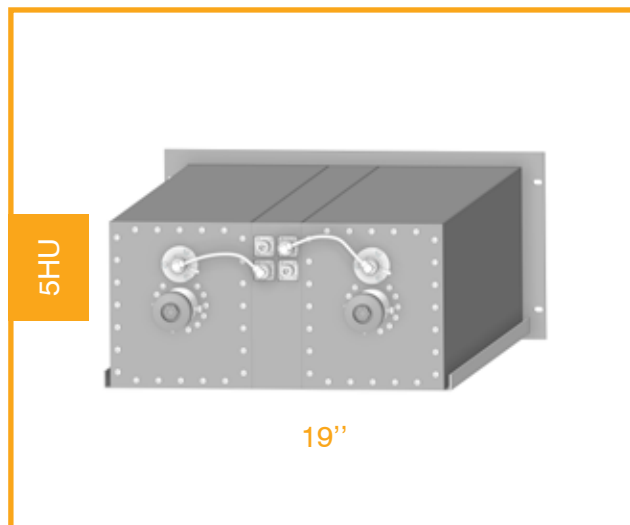

Electrical Specifications

Frequency band:	118 - 144 MHz
Impedance:	50 Ω
Max Power:	100W CW
Insertion loss:	Adjustable 0.5 ÷ 2.5 dB

Mechanical Specifications

Connector Type:	N Female
Dimensions:	19" rack, 5HU, depth 684 mm
Operating temp.:	-10°C to +55°C
Tuning method:	Rotary knob, telescopic movement

Notch Filters	Channels	Cabinet 5HU	Frequency Spacing (kHz)	Attenuation dB
MCP210-V/2 TI F04VR210M1HSxxxx	1	1	50	≥ 25
			100	≥ 30
			200	≥ 40
			300	≥ 40

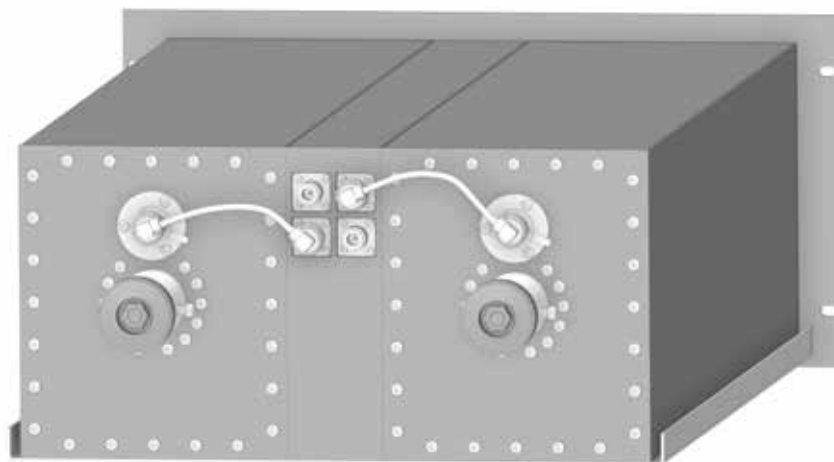

MCP210-V/2TI

Notch Filters VHF

180 rectangular cavity

The Notch Filter is used when high attenuation is required for narrow spacing between the working and the rejected frequency in the VHF range. Attenuation and Insertion Loss can be adjusted by the rotating loops of the cavity. It is used for frequency spacing of 300 kHz or less. It is installed in a single 4 unit 19" cabinet.

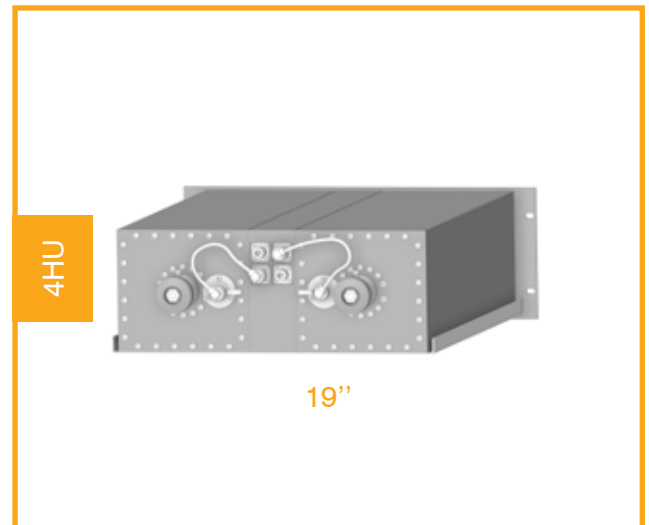

Electrical Specifications

Frequency band:	118 - 144 MHz
Impedance:	50 Ω
Max Power:	100W CW
Insertion loss:	Adjustable 0.5 ÷ 2.5 dB

Mechanical Specifications

Connector Type:	N Female
Dimensions:	19" rack, 4HU, depth 670 mm
Operating temp.:	-10°C to +55°C
Tuning method:	Rotary knob, telescopic movement

Notch Filters	Channels	Cabinet 4HU	Frequency Spacing (kHz)	Attenuation dB
MCP180-V/2 TI F04VR180M1HSxxxx	1	1	100	≥ 25
			200	≥ 30
			300	≥ 40

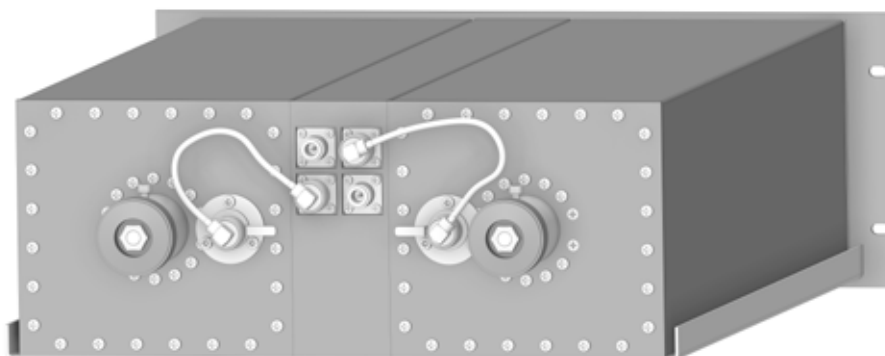

MCP180-V/2TI

COMBINERS

VHF

STAR 080 double cavity

Combiners allow several radio channels to operate at one site using a common antenna. The MCPS 080 Star Combiners are composed by 080 VHF cavities and a star connection combining from 2 to 4 channels in the VHF range. The input and output loops can be adjusted for the optimum combination of selectivity and insertion loss.

Electrical Specifications

Frequency band:	112 - 157 MHz
Impedance:	50 Ω
Input Power:	100W CW
Insertion loss:	Adjustable rotating loop, window coupling

Mechanical Specifications

Connector Type:	N Female
Dimensions:	19" rack, 4HU, depth 690 mm
Operating temp.:	-10°C to +55°C
Tuning method:	Rotary knob, telescopic inner movement

Combiners	Channels	Cabinet 2HU	Total Height (HU)	Attenuation
MCPS080-V/4-4W F06ER080M4SDxxxx	4	2	4	> 20dB @ $\pm 0.4\%$ offset from f_0

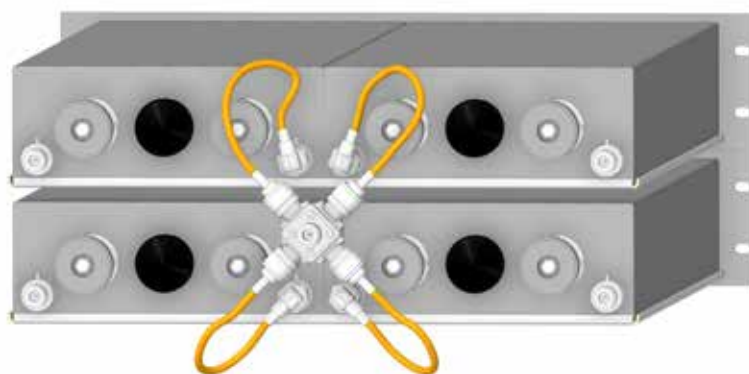

MCPS080-V/4-4W

Combiners VHF

STAR 100 single cavity

Combiners allow several radio channels to operate at one site using a common antenna. The MCP 100 Star Combiners are composed by 100 VHF round cavities and a star connection combining from 2 to 4 channels in the VHF range. The input and output loops can be adjusted for the optimum combination of selectivity and insertion loss.

Electrical Specifications

Frequency band:	118 - 156 MHz
Impedance:	50 Ω
Input Power:	100W CW
Insertion loss:	\leq 2dB

Mechanical Specifications

Connector Type:	N Female
Dimensions:	19" rack, 4-6HU, depth 620 mm
Operating temp.:	-10°C to +55°C
Tuning method:	non telescopic movement

Combiners	Attenuation	Spacing (%Fo)	Thermal Stability (ppm°C)	Input Power (CW)
MCP100-V/2 F06SC100M2Sxxxx	12dB \pm 0.75%Fo 1dB I.L.	0.33	3	100W
MCP100-V/3 F06SC100M3Sxxxx	12dB \pm 0.75%Fo 1dB I.L.	0.33	3	100W
MCP100-V/4 F06SC100M4Sxxxx	12dB \pm 0.75%Fo 1dB I.L.	0.33	3	100W

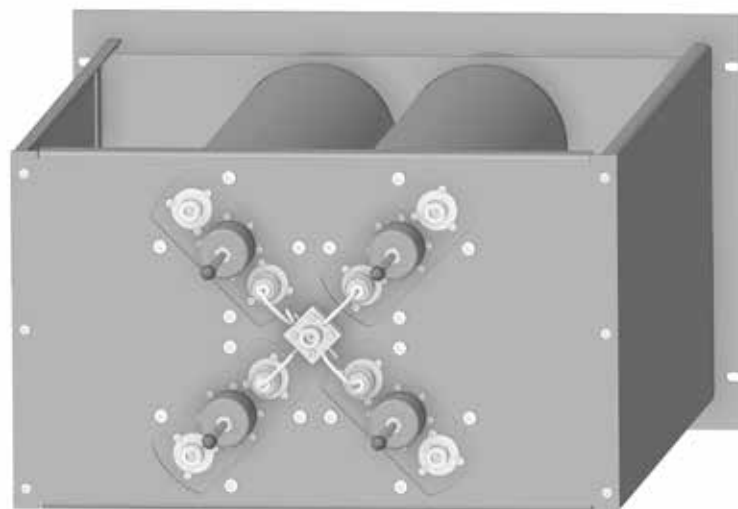

MCP100-V/4

STAR 120 single cavity

Combiners allow several radio channels to operate at one site using a common antenna. The MCPS 120 V Star Combiners are composed by 120mm cavities and a star connection combining from 2 to 6 channels in the VHF range. The input and output loops can be adjusted for the optimum combination of selectivity and insertion loss. Four cavities can be placed in a standard 3 unit 19" cabinet.

Electrical Specifications

Frequency band:	112 - 156 MHz
Impedance:	50 Ω
Input Power:	100W CW
Insertion loss:	Adjustable 1 ÷ 3.5 dB

Mechanical Specifications

Connector Type:	N Female
Dimensions:	19" rack, 3HU, depth 728 mm
Operating temp.:	-10°C to +55°C
Tuning method:	Rotary knob, telescopic inner movement

Combiners	Channels	Cabinet 3HU	Total height HU	Attenuation dB ±500 kHz at 127.5 MHz
MCPS120-V/2 F06ER120M2SSxxxx	2	1	3	≥ 11
MCPS120-V/3 F06ER120M3SSxxxx	3	1	3	≥ 11
MCPS120-V/4 F06ER120M4SSxxxx	4	1	3	≥ 11
MCPS120-V/5 F06VR120M5SSxxxx	5	2	6	≥ 11
MCPS120-V/6 F06VR120M6SSxxxx	6	2	6	≥ 11

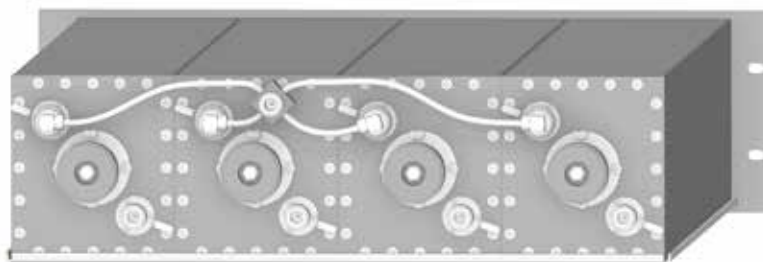

MCPS120-V/4

STAR 120 double cavity

Combiners allow several radio channels to operate at one site using a common antenna. The MCPS 120 V double cavity star combiners are composed by two 120mm cavities and a star connection combining from 2 to 6 channels in the VHF range. Two cavities are connected in series to improve selectivity. The input and output loops can be adjusted for the optimum combination of selectivity and insertion loss. Four cavities can be placed in a standard 3 unit 19" cabinet.

Electrical Specifications

Frequency band:	112 - 156 MHz
Impedance:	50 Ω
Input Power:	100W CW
Insertion loss:	Adjustable 2 ÷ 4.5 dB

Mechanical Specifications

Connector Type:	N Female
Dimensions:	19" rack, 3HU, depth 728 mm
Operating temp.:	-10°C to +55°C
Tuning method:	Rotary knob, telescopic movement

Combiners	Channels	Cabinet 3HU	Total height HU	Attenuation dB ± 500 kHz at 127.5 MHz
MCPS120-V/2-2 F06ER120M2SDxxxx	2	1	3	≥ 25
MCPS120-V/3-3 F06ER120M3SDxxxx	3	2	6	≥ 25
MCPS120-V/4-4 F06ER120M4SDxxxx	4	2	6	≥ 25
MCPS120-V/5-5 F06VR120M5SDxxxx	5	3	9	≥ 25
MCPS120-V/6-6 F06VR120M6SDxxxx	6	3	9	≥ 25

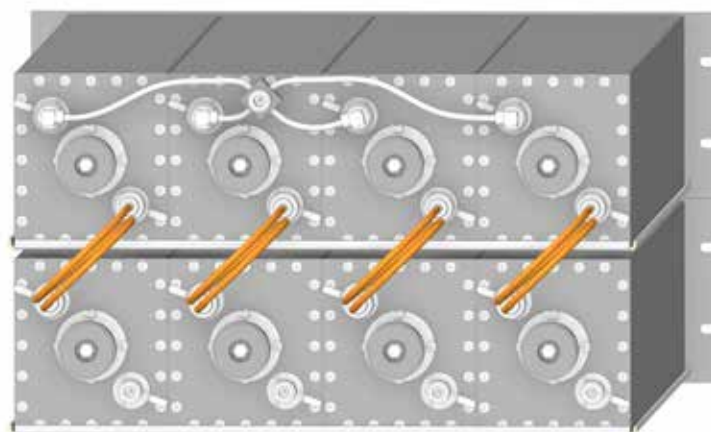

MCPS120-V/4-4

STAR 165 single cavity

Combiners are a vital system component for improving the quality of ATC radio communications. They are used to allow several radio channels to operate at the same site using a common antenna thus saving installation space. Their high power rating make them ideal for working with AM transmitters with high peak power. The combiner can be adjusted to obtain the optimum combination of selectivity and insertion loss. The combiners can be supplied with or without external isolators. The Star Combiners are installed in one or more 4 units 19" standard cabinets.

Electrical Specifications

Frequency band:	118 - 156 MHz
Impedance:	50 Ω
Input Power:	100W CW
Insertion loss:	Adjustable 1 ÷ 3.5 dB

Mechanical Specifications

Connector Type:	N Female
Dimensions:	19" rack, 4HU, depth 670 mm
Operating temp.:	-10°C to +55°C
Tuning method:	Rotary knob, telescopic movement

Combiners	Channels	Cabinet 4HU	Total height HU	Attenuation dB ±500 kHz at 127.5 MHz
MCPS165-V/2 F06VR165M2SSxxxx	2	1	4	≥ 15
MCPS165-V/3 F06VR165M3SSxxxx	3	2	8	≥ 15
MCPS165-V/4 F06VR165M4SSxxxx	4	2	8	≥ 15
MCPS165-V/5 F06VR165M5SSxxxx	5	3	12	≥ 15
MCPS165-V/6 F06VR165M6SSxxxx	6	3	12	≥ 15

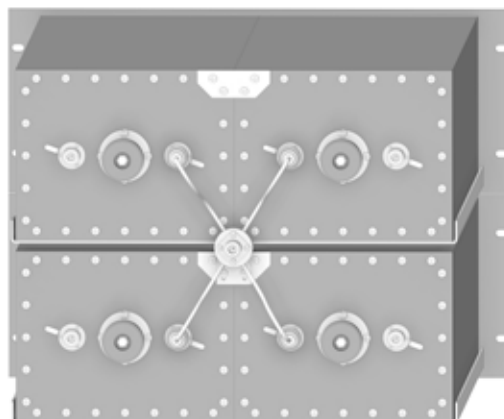

MCPS165-V/4

Combiners VHF

STAR 165 double cavity

Combiners are a vital system component for improving the quality of ATC radio communications. They are used to allow several radio channels to operate at the same site using a common antenna thus saving installation space. Each channel consists of two cavities connected in series. Their high power rating make them ideal for working with AM transmitters with high peak power. The combiner can be adjusted to obtain the optimum combination of selectivity and insertion loss. The combiners can be supplied with or without external isolators. The Star Combiners are installed in more 4 units 19" standard cabinets.

Electrical Specifications

Frequency band:	118 - 156 MHz
Impedance:	50 Ω
Input Power:	100W CW
Insertion loss:	Adjustable 1.5 ÷ 4 dB

Mechanical Specifications

Connector Type:	N Female
Dimensions:	19" rack, 4HU, depth 670 mm
Operating temp.:	-10°C to +55°C
Tuning method:	Rotary knob, telescopic movement

Combiners	Channels	Cabinet 4HU	Total height HU	Attenuation dB ± 500 kHz at 127.5 MHz
MCPS165-V/2-2 F06VR165M2SDxxxx	2	2	8	≥ 30
MCPS165-V/3-3 F06VR165M3SDxxxx	3	3	12	≥ 30
MCPS165-V/4-4 F06VR165M4SDxxxx	4	4	16	≥ 30
MCPS165-V/5-5 F06VR165M5SDxxxx	5	5	20	≥ 30
MCPS165-V/6-6 F06VR165M6SDxxxx	6	6	24	≥ 30

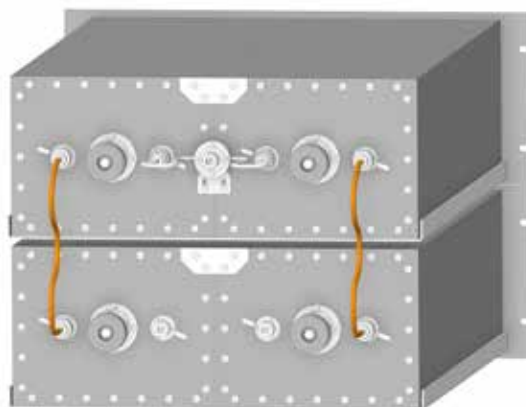

MCPS165-V/2-2

STAR 180 single cavity

Combiners are a vital system component for improving the quality of ATC radio communications. They are used to allow several radio channels to operate at the same site using a common antenna thus saving installation space. Their high power rating make them ideal for working with AM transmitters with high peak power. The combiner can be adjusted to obtain the optimum combination of selectivity and insertion loss. The combiners can be supplied with or without external isolators. The Star Combiners are installed in one or more 4 units 19" standard cabinets.

Electrical Specifications

Frequency band:	118 - 156 MHz
Impedance:	50 Ω
Input Power:	200W CW
Insertion loss:	Adjustable 1 ÷ 3.5 dB

Mechanical Specifications

Connector Type:	N Female
Dimensions:	19" rack, 4HU, depth 670 mm
Operating temp.:	-10°C to +55°C
Tuning method:	Rotary knob, telescopic movement

Combiners	Channels	Cabinet 4HU	Total height HU	Attenuation dB ±0.4% Fo
MCPS180-V/2 F06VR180M2SSxxxx	2	1	4	≥ 13
MCPS180-V/3 F06VR180M3SSxxxx	3	2	8	≥ 13
MCPS180-V/4 F06VR180M4SSxxxx	4	2	8	≥ 13
MCPS180-V/5 F06VR180M5SSxxxx	5	3	12	≥ 13
MCPS180-V/6 F06VR180M6SSxxxx	6	3	12	≥ 13

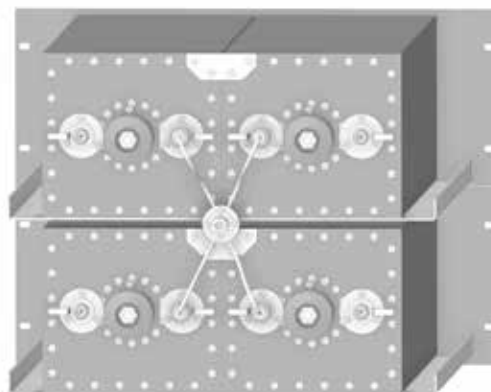

MCPS180-V/4

Combiners VHF

STAR 180 double cavity

Combiners are a vital system component for improving the quality of ATC radio communications. They are used to allow several radio channels to operate at the same site using a common antenna thus saving installation space. Each channel consists of two cavities connected in series. Their high power rating make them ideal for working with AM transmitters with high peak power. The combiner can be adjusted to obtain the optimum combination of selectivity and insertion loss. The combiners can be supplied with or without external isolators. The Star Combiners are installed in more 4 units 19" standard cabinets.

Electrical Specifications

Frequency band:	118 - 156 MHz
Impedance:	50 Ω
Input Power:	200W CW
Insertion loss:	Adjustable 1.5 ÷ 4 dB

Mechanical Specifications

Connector Type:	N Female
Dimensions:	19" rack, 4HU, depth 670 mm
Operating temp.:	-10°C to +55°C
Tuning method:	Rotary knob, telescopic movement

Combiners	Channels	Cabinet 4HU	Total height HU	Attenuation dB ± 500 kHz at 127.5 MHz
MCPS180-V/2-2 F06VR180M2SDxxxx	2	2	8	≥ 26
MCPS180-V/3-3 F06VR180M3SDxxxx	3	3	12	≥ 26
MCPS180-V/4-4 F06VR180M4SDxxxx	4	4	16	≥ 26
MCPS180-V/5-5 F06VR180M5SDxxxx	5	5	20	≥ 26
MCPS180-V/6-6 F06VR180M6SDxxxx	6	6	24	≥ 26

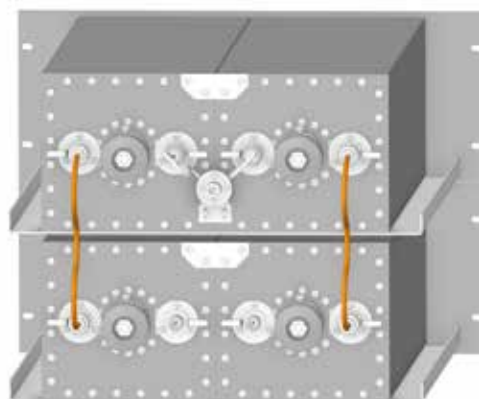

MCPS180-V/2-2

STAR 200 single cavity

Combiners allow several radio channels to operate at one site using a common antenna. The MCP 200 Star Combiners are composed by 200 VHF round cavities and a star connection combining two channels in the VHF range. The input and output loops can be adjusted for the optimum combination of selectivity and insertion loss.

Electrical Specifications

Frequency band:	118 - 156 MHz
Impedance:	50 Ω
Input Power:	100W CW
Insertion loss:	Adjustable 1.5 ÷ 4.5 dB

Mechanical Specifications

Connector Type:	N Female
Dimensions:	19" rack, 5HU, depth 625 mm
Operating temp.:	-10°C to +55°C
Tuning method:	Rotary knob, non telescopic movement

Combiners	Channels	Cabinet 5HU	Total Height (HU)	Attenuation dB ± 500kHz @ 127MHz
MCP200-V/2 F06SC200M2Sxxxx	2	1	5	≥ 15
MCP200-V/3 F06SC200M3Sxxxx	3	2	10	≥ 15
MCP200-V/4 F06SC200M4Sxxxx	4	2	10	≥ 15
MCP200-V/5 F06SC200M5Sxxxx	5	3	15	≥ 15
MCP200-V/6 F06SC200M6Sxxxx	6	3	15	≥ 15

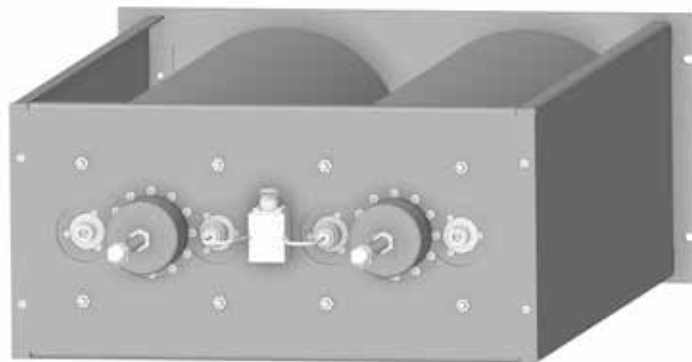

MCP200-V/2

STAR 210 single cavity

Combiners allow several radio channels to operate at one site using a common antenna. The MCPS 210 V Star Combiners are composed by 210mm cavities and a star connection combining from 2 to 6 channels in the VHF range. Their high power rating make them ideal for working with AM transmitters with high peak power. The input and output loops can be adjusted for the optimum combination of selectivity and insertion loss. The combiners can be supplied with or without external isolators.

Electrical Specifications

Frequency band:	118 - 156 MHz
Impedance:	50 Ω
Input Power:	200W CW
Insertion loss:	Adjustable 1 ÷ 3.5 dB

Mechanical Specifications

Connector Type:	N Female
Dimensions:	19" rack, 5HU, depth 670 mm
Operating temp.:	-10°C to +55°C
Tuning method:	Rotary knob, telescopic movement

Combiners	Channels	Cabinet 5HU	Total height HU	Attenuation dB ±500 kHz at 127.5 MHz
MCPS210-V/2 F06VS210M2SSxxxx	2	1	5	≥ 15
MCPS210-V/3 F06VS210M3SSxxxx	3	2	10	≥ 15
MCPS210-V/4 F06VS210M4SSxxxx	4	2	10	≥ 15
MCPS210-V/5 F06VS210M5SSxxxx	5	3	15	≥ 15
MCPS210-V/6 F06VS210M6SSxxxx	6	3	15	≥ 15

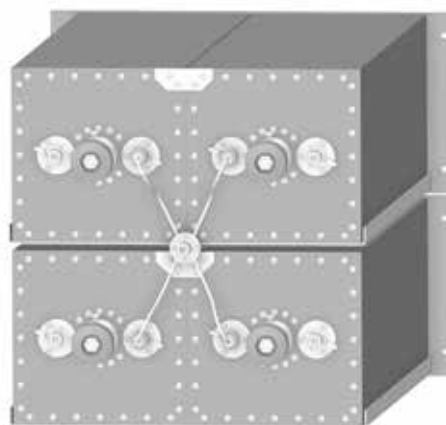

MCPS210-V/4

STAR 210 double cavity

Combiners allow several radio channels to operate at one site using a common antenna. The MCPS 210 V double cavity star combiners are composed by 210mm cavities and a star connection combining from 2 to 6 channels in the VHF range. Two cavities are connected in series to improve selectivity. Their high power rating make them ideal for working with AM transmitters with high peak power. The input and output loops can be adjusted for the optimum combination of selectivity and insertion loss. The combiners can be supplied with or without external isolators.

Electrical Specifications

Frequency band:	118 - 156 MHz
Impedance:	50 Ω
Input Power:	200W CW
Insertion loss:	Adjustable 1.5 ÷ 4 dB

Mechanical Specifications

Connector Type:	N Female
Dimensions:	19" rack, 5HU, depth 670 mm
Operating temp.:	-10°C to +55°C
Tuning method:	Rotary knob, telescopic movement

Combiners	Channels	Cabinet 5HU	Total height HU	Attenuation dB ±500 kHz at 127.5 MHz
MCPS210-V/2-2 F06VS210M2SDxxxx	2	2	10	≥ 32
MCPS210-V/3-3 F06VS210M3SDxxxx	3	3	15	≥ 32
MCPS210-V/4-4 F06VS210M4SDxxxx	4	4	20	≥ 32
MCPS210-V/5-5 F06VS210M5SDxxxx	5	5	25	≥ 32
MCPS210-V/6-6 F06VS210M6SDxxxx	6	6	30	≥ 32

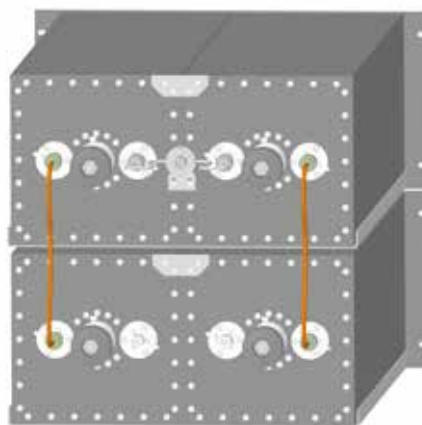

MCPS210-V/2-2

MANIFOLD 210 double cavity

Combiners allow several radio channels to operate at one site using a common antenna. The MCP 210 V manifold combiner uses an alternative method for combining up to 4 channels in the VHF range. The number of channels can be increased or decreased upon request. A double band pass filter with adjustable window coupling is used for each channel. Each channel is allocated in a single 5 unit 19" cabinet.

Electrical Specifications

Frequency band:	118 - 144 MHz
Impedance:	50 Ω
Input Power:	200W CW
Insertion loss:	Adjustable 1.5 ÷ 4 dB

Mechanical Specifications

Connector Type:	N Female
Dimensions:	19" rack, 5HU, depth 670 mm
Operating temp.:	-10°C to +55°C
Tuning method:	Rotary knob, telescopic movement

Combiners	Channels	Cabinet 5HU	Total height HU	Attenuation dB ±500 kHz at 127.5 MHz
MCP210-V/2-2 F06VS210M2MDxxxx	2	2	10	≥ 32
MCP210-V/3-3 F06VS210M3MDxxxx	3	3	15	≥ 32
MCP210-V/4-4 F06VS210M4MDxxxx	4	4	20	≥ 32

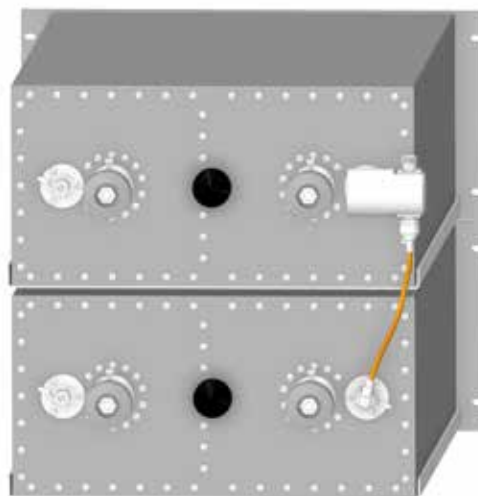

MCP210-V/2-2

DOUBLE BRIDGE 180 cavity

Combiners allow several radio channels to operate at one site using a common antenna. The MCPD 180 V double bridge combiners guarantee isolation between channels with respect to manifold or starpoint combiners. They are composed by two 180 VHF cavities and two hybrid devices. Expansion of channels is done easily in the field without need of instrumentation or cavity retuning. Each channel is allocated in a single 4 unit 19" cabinet. Up to 10 channels in the VHF range can be installed in a 42 units, 19" standard rack.

Electrical Specifications

Frequency band:	118 - 144 MHz
Impedance:	50 Ω
Input Power:	200W CW
Insertion loss:	Adjustable 1.5 ÷ 3.5 dB

Mechanical Specifications

Connector Type:	N Female
Dimensions:	19" rack, 4HU, depth 700 mm
Operating temp.:	-10°C to +55°C
Tuning method:	Rotary knob, telescopic movement

Combiners	Channels	Cabinet 4HU	Attenuation
MCPD180-V#	1 ÷ 10	1 ÷ 10	13dB ±500 kHz at 127.5 MHz

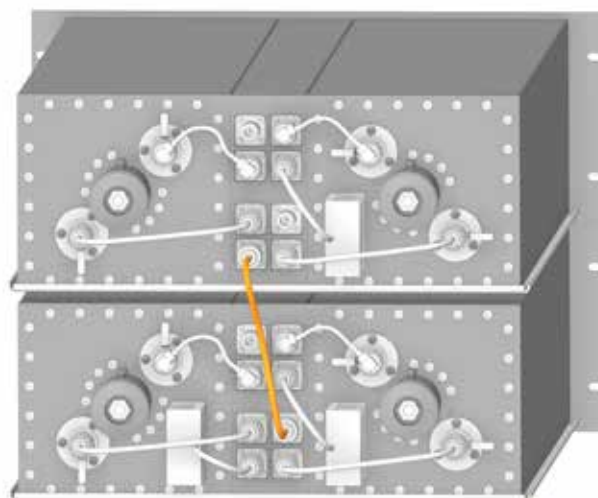

MCPD180-V/2
F06VR180M2DSxxxx

DOUBLE BRIDGE 180 cavity high selectivity

Combiners allow several radio channels to operate at one site using a common antenna. The MCPD 180 V high selectivity double bridge combiners guarantee higher selectivity and isolation between channels. Each channel is composed by three 180 VHF cavities and two hybrid devices. Expansion of channels is done easily in the field without need of instrumentation or cavity retuning. Up to 5 channels in the VHF range can be installed in 32 units, 19" standard rack.

Electrical Specifications

Frequency band:	118 - 144 MHz
Between channels isolation:	> 60 dB @ +/- 1% Fo
Input Power:	100W CW
Insertion loss:	Adjustable 2 ÷ 3.5 dB

Mechanical Specifications

Connector Type:	N Female
Dimensions for each channel:	19" rack, 4HU, depth 700 mm
Operating temp.:	-10°C to +55°C
Tuning method:	Rotary knob, telescopic movement

Combiners	Channels	Cabinet 4HU	Attenuation
MCPD180-V#	2 ÷ 5	8 ÷ 32	>40dB @ ± 1% f ₀

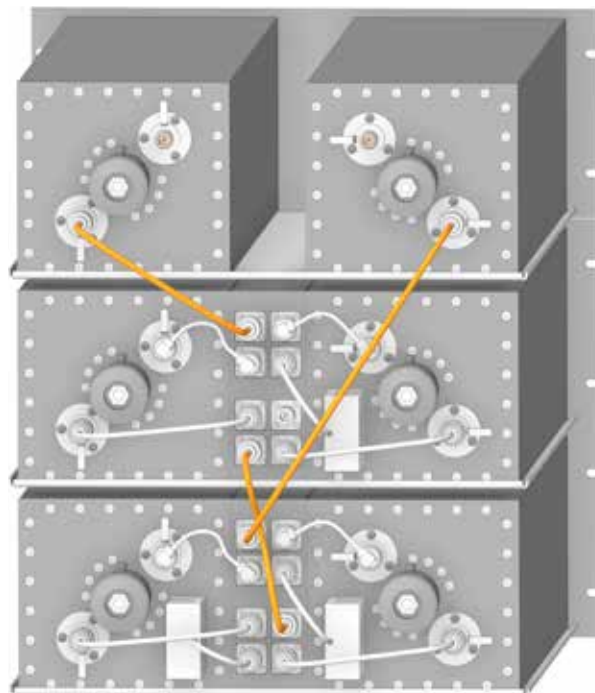

MCPD180-V/2-2
F06VR180M2DDxxxx

DOUBLE BRIDGE 280 cavity

Combiners allow several radio channels to operate at one site using a common antenna. The MCPD 280 V double bridge combiners guarantee isolation between channels with respect to manifold or starpoint combiners. They are composed by two 280mm VHF cavities and two hybrid devices. Expansion of channels is done easily in the field without need of instrumentation or cavity retuning. Each channel is allocated in a single 5 unit cabinet. Up to 8 channels in the VHF range can be installed in a 42 units, 25" standard rack. Additional channels (up to 16) can be added.

Electrical Specifications

Frequency band:	118 - 144 MHz
Impedance:	50 Ω
Input Power:	100W CW
Insertion loss:	Adjustable 1 ÷ 3.5 dB

Mechanical Specifications

Connector Type:	N Female or 7/16
Dimensions:	25" rack, 5HU, depth 700 mm
Operating temp.:	-10°C to +55°C
Tuning method:	Rotary knob, telescopic movement

Combiners	Channels	Cabinet 5HU	Attenuation
MCPD280-V#	1 ÷ 16	1 ÷ 16	14dB \pm 200 kHz at 127.5 MHz

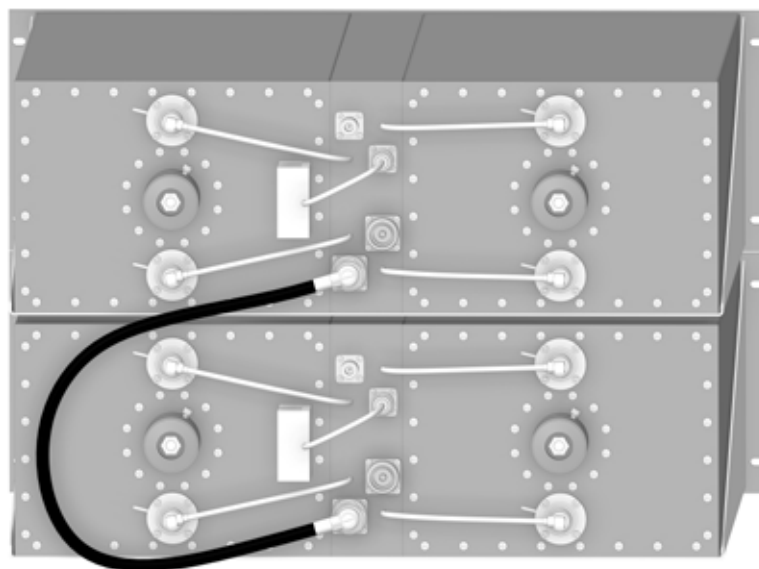

MCPD280-V/2



COMBINERS

UHF

Combiners UHF

STAR 100 single cavity

Combiners allow several radio channels to operate at one site using a common antenna. The MCP 100 Star Combiners are composed by 100 UHF round cavities and a star connection combining two channels in the UHF range. The input and output loops can be adjusted for the optimum combination of selectivity and insertion loss.

Electrical Specifications

Frequency band:	225 - 400 MHz
Impedance:	50 Ω
Max Power:	100W CW
Insertion loss:	< 2dB

Mechanical Specifications

Connector Type:	N Female
Dimensions:	19" rack, 4/6 HU, depth 620 mm
Operating temp.:	-10°C to +55°C
Tuning method:	Rotary knob, non telescopic movement

Cavity	Model	Attenuation	Spacing (%Fo)	Thermal Stability (ppm°C)	Input Power (CW)
100	MCP100-U/2 F06UC100M2SSxxxx	12dB \pm 0.75%Fo 1dB I.L.	0.33	5	100W
	MCP100-U/3 F06UC100M3SSxxxx	12dB \pm 0.75%Fo 1dB I.L.	0.33	5	100W
	MCP100-U/4 F06UC100M4SSxxxx	12dB \pm 0.75%Fo 1dB I.L.	0.33	5	100W

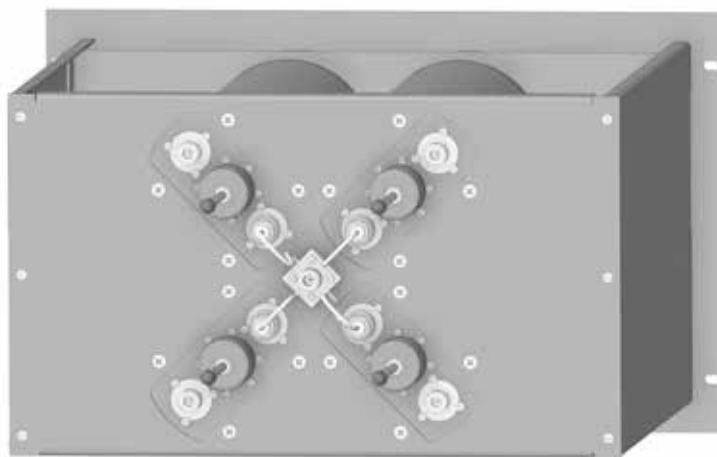

MCP100-U/4

Combiners UHF

STAR 120 single cavity

Combiners allow several radio channels to operate at one site using a common antenna. The MCPS 120 U/2 star combiner is composed by 120 mm cavities and a star connection which combines two channels in the UHF range. The input and output loops can be adjusted for the optimum combination of selectivity and insertion loss.

Electrical Specifications

Frequency band:	225 - 400 MHz
Impedance:	50 Ω
Max Power:	100W CW
Insertion loss:	Adjustable 1 ÷ 3 dB

Mechanical Specifications

Connector Type:	N Female
Dimensions:	19" rack, 3 HU
Operating temp.:	-10°C to +55°C
Tuning method:	Rotary knob, telescopic movement

Combiners	Channels	Cabinet 3HU	Total height HU	Attenuation
MCPS120-U/2 F06UR120M2SSxxxx	2	1	3 - depth 560 mm	> 13 dB \pm 0.4% at 312 MHz
MCPS120-U/3 F06UR120M3SSxxxx	3	1	3 - depth 560 mm	> 13 dB \pm 0.4% at 312 MHz

Combiners	Channels	Cabinet 6HU	Total height HU	Attenuation
MCPS120-U/4R F06UR120M4SSxxxx	4	1/2	6 - depth 560 mm	> 16 dB at \pm 1% from f_0

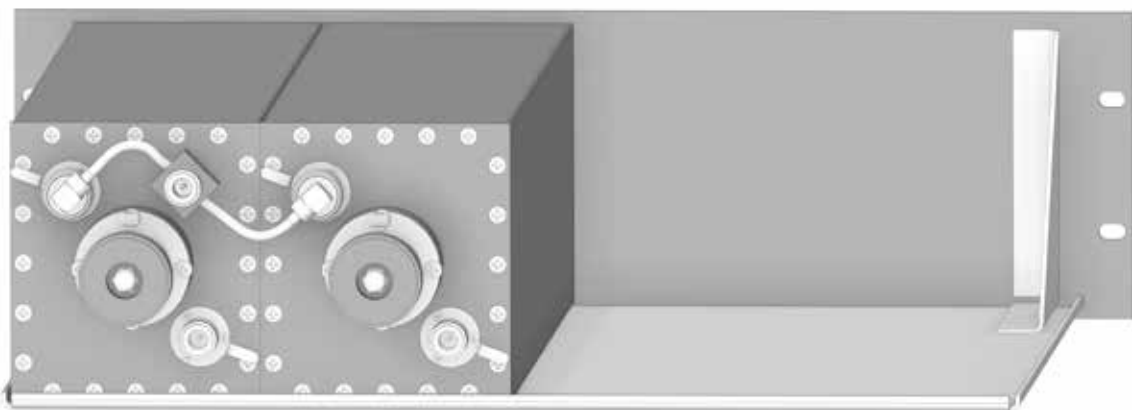

MCPS120-U/2

Combiners UHF

STAR 210 single cavity

Combiners allow several radio channels to operate at one site using a common antenna. The MCPS 210 U/2 star combiner is composed by two 210 mm cavities and a star connection which combines two channels in the UHF range. The input and output loops can be adjusted for the optimum combination of selectivity and insertion loss.

Electrical Specifications

Frequency band:	225 - 400 MHz
Impedance:	50 Ω
Max Power:	200W CW
Insertion loss:	Adjustable 1 ÷ 3 dB

Mechanical Specifications

Connector Type:	N Female
Dimensions:	19" rack, 5HU, depth 600 mm
Operating temp.:	-10°C to +55°C
Tuning method:	Rotary knob, telescopic movement

Combiners	Channels	Cabinet 5HU	Total height HU	Attenuation
MCPS210-U/2 F06US210M2SSxxxx	2	1	5	> 17 dB \pm 0.4%
MCPS210-U/3 F06US210M3SSxxxx	3	2	10	> 17 dB \pm 0.4%
MCPS210-U/4 F06US210M4SSxxxx	4	2	10	> 17 dB \pm 0.4%

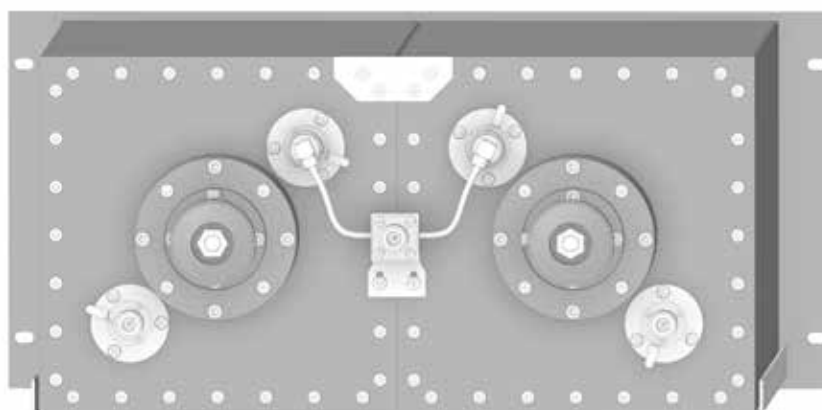

MCPS210-U/2

Combiners UHF

STAR 210 double cavity

Combiners allow several radio channels to operate at one site using a common antenna. The MCPS 210 U/2 star combiner is composed by two 210 mm cavities and a star connection which combines two channels in the UHF range. The input and output loops can be adjusted for the optimum combination of selectivity and insertion loss.

Electrical Specifications

Frequency band:	225 - 400 MHz
Impedance:	50 Ω
Max Power:	200W CW
Insertion loss:	< 2.0 dB

Mechanical Specifications

Connector Type:	N Female
Dimensions:	19" rack, 10HU, depth 600 mm
Operating temp.:	-10°C to +55°C
Tuning method:	Rotary knob, telescopic movement

Combiners	Channels	Cabinet 5HU	Total height HU	Attenuation
MCPS210-U/2-2 F06US210M2SDxxxx	2	2	10	> 32 dB @ \pm 1.2 MHz
MCPS210-U/3-3 F06US210M3SDxxxx	3	4	20	> 32 dB @ \pm 1.2 MHz
MCPS210-U/4-4 F06US210M4SDxxxx	4	4	20	> 32 dB @ \pm 1.2 MHz

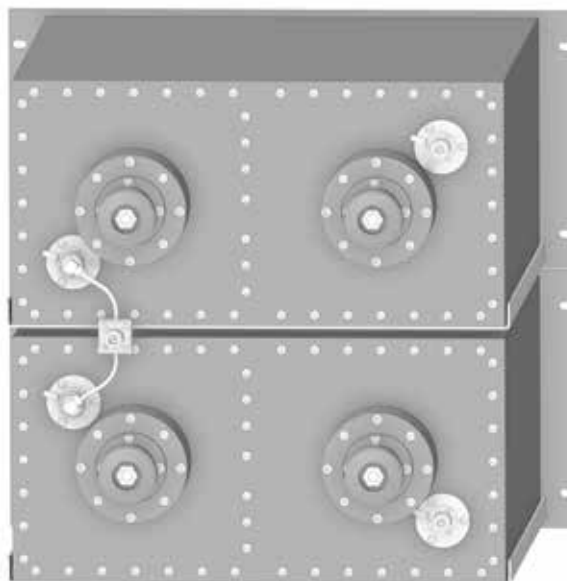

MCPS210-U/2-2

DOUBLE BRIDGE 120 cavity

Combiners allow several radio channels to operate at one site using a common antenna. The MCPD 120 U double bridge combiners guarantee isolation between channels with respect to manifold or starpoint combiners. They are composed by two 120mm VHF cavities and two hybrid devices. Expansion of channels is done easily in the field without need of cavity retuning. Each channel is allocated in a single 3 unit 19" cabinet. Up to 8 channels in the UHF range can be installed in a 19" standard rack.

Electrical Specifications

Frequency band:	250 - 400 MHz
Between channels isolation:	50 Ω
Input Power:	100W CW
Insertion loss:	Adjustable 1 ÷ 3.5 dB

Mechanical Specifications

Connector Type:	N Female
Dimensions:	19" rack, 3HU, depth 560 mm
Operating temp.:	-10°C to +55°C
Tuning method:	Rotary knob, telescopic movement

Combiners	Channels	Cabinet 3HU	Attenuation
MCPD120-U#	1 ÷ 8	1 ÷ 8	19dB \pm 1% f_0

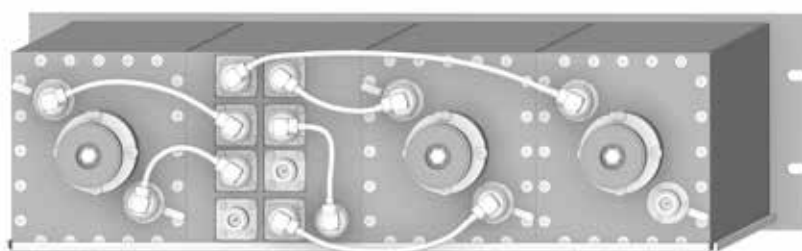

MCPD120-U/2
F06UR120M2DSxxxx

DOUBLE BRIDGE 120 cavity high selectivity

Combiners allow several radio channels to operate at one site using a common antenna. The MCPD 120 U high selectivity double bridge combiners guarantee higher selectivity and isolation between channels. Each channel is composed by three 120 mm UHF cavities and two hybrid devices. Expansion of channels is done easily in the field without need of cavity retuning. Up to 4 channels in the UHF range can be installed in 12 units, 19" standard rack.

Electrical Specifications

Frequency band:	225 - 400 MHz
Between channels isolation:	>50 dB @ +/-1% Fo
Input Power:	100W CW
Insertion loss:	Adjustable 1 ÷ 3.5 dB

Mechanical Specifications

Connector Type:	N Female or 7/16
Dimensions for each channel:	19" rack, 3HU, depth 560 mm
Operating temp.:	-10°C to +55°C
Tuning method:	Rotary knob, telescopic movement

Combiners	Channels	Cabinet 3HU	Attenuation
MCPD120-U#	2 ÷ 4	2 ÷ 4	>40dB @ ±1% f ₀

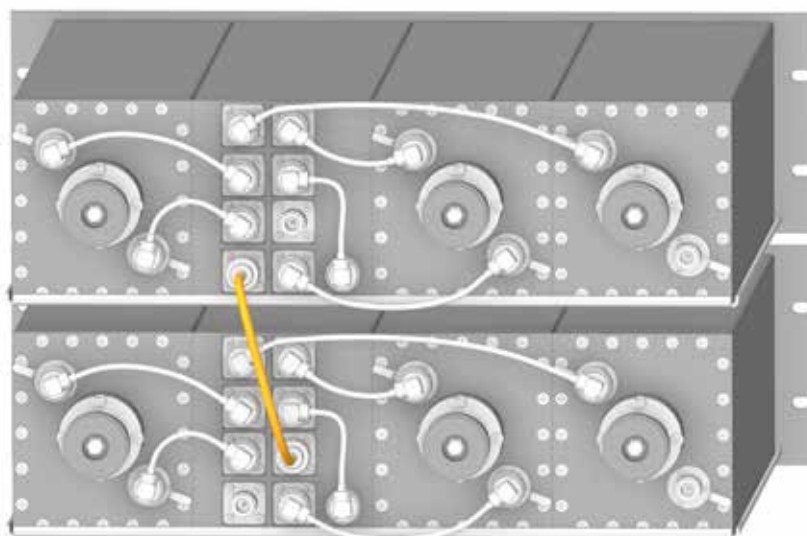

MCPD120-U/2-2
F06UR120M2DDxxxx

Combiners UHF

280 cavity

Combiners allow several radio channels to operate at one site using a common antenna. The MCPD 280 U double bridge combiner guarantees isolation between channels with respect to manifold or starpoint combiners. It is composed by two 280mm UHF cavities and two hybrid devices. Expansion of channels is done easily in the field without need of instrumentation or filter retuning. Each channel is allocated in a single 5 unit cabinet. Up to 8 channels can be installed in a 42 units, 25" standard rack.

Electrical Specifications

Frequency band:	225 - 400 MHz
Impedance:	50 Ω
Input Power:	100W CW
Insertion loss:	Adjustable 1 ÷ 3.5 dB

Mechanical Specifications

Connector Type:	N Female or 7/16
Dimensions for each channel:	25" rack, 5HU, depth 600 mm
Operating temp.:	-10°C to +55°C
Tuning method:	Rotary knob, telescopic movement

Combiners	Channels	Cabinet 5HU	Attenuation
MCPD280-U#	1 ÷ 8	1 ÷ 8	13dB \pm 500 kHz at 312 MHz

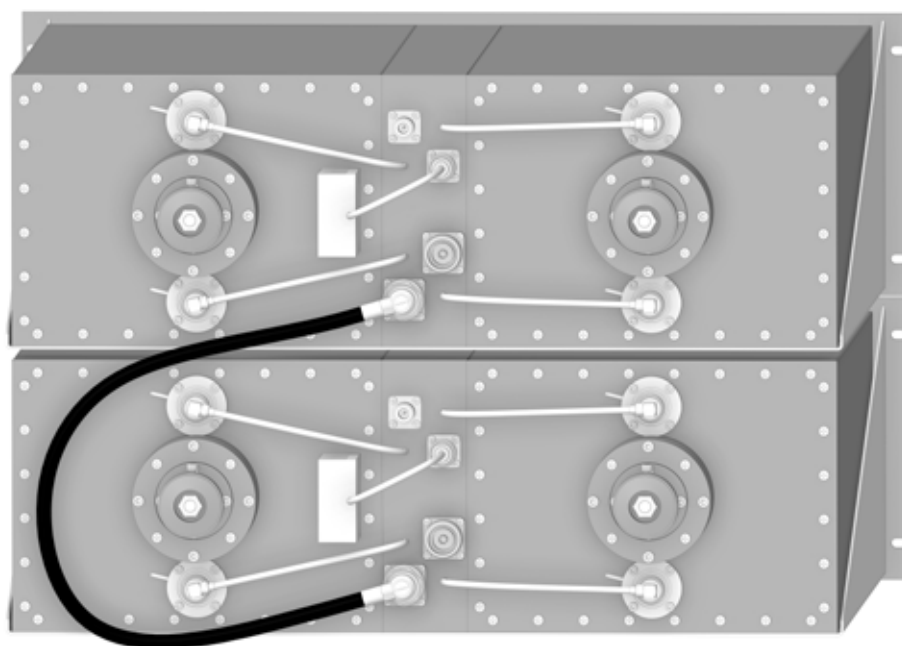

MCPD280-U/2



AUTOMATIC
TUNING
BAND PASS
FILTERS

VHF

Automatic Tuning Band Pass Filters VHF

085 double cavity window coupled

2 units height, window coupled double cavity automatic tuning filters are a key factor when space is limited. High selectivity, extended frequency range and fast tuning time allow for easy operation on the field. The independent tuning capability and accuracy offer optimum software controlled matching performance. Customized control interfaces available.

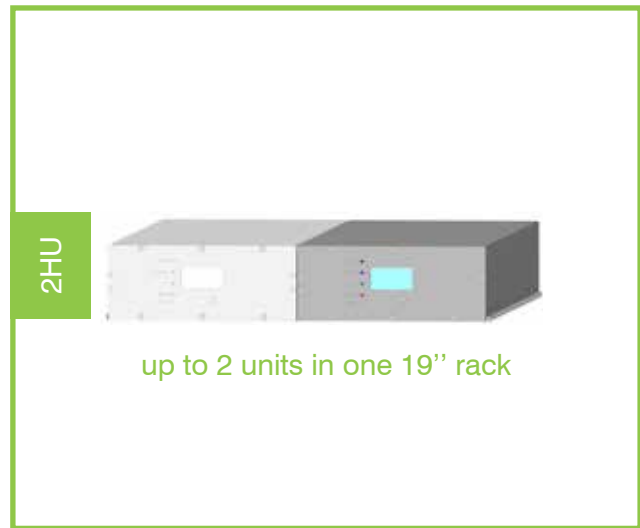

Electrical Specifications

Frequency band:	112 - 156 MHz
Impedance:	50 Ω
Max Power:	50W CW
Interfaces:	Ethernet, RS485 or RS422

Mechanical Specifications

Connector Type:	N Female
Dimensions (VHF):	1/2 19" rack, 2HU depth. 580 mm
Operating temp.:	-10°C to +55°C
Tuning method:	Automatic, telescopic movement

Automatic Band Pass Filter	VSWR	Tuning time	Insertion Loss	Selectivity
FPBA085-V/2 F02ER085A1WDxxxx	< 1.6:1	Typ. 7 Sec.	< 2dB	> 20 dB @ $\pm 0.4\% f_0$ > 35 dB @ $\pm 1\% f_0$

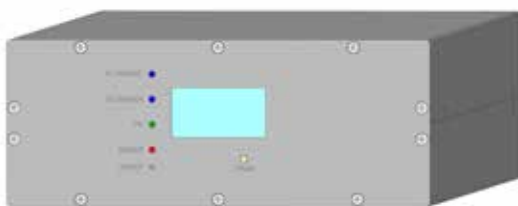

FPBA085-V/2
front view



FPBA085-V/2
rear view

Automatic Tuning Band Pass Filters VHF

210 single cavity

5 units single cavity automatic tuning filters are a key factor in emergencies. High selectivity, extended frequency range and fast tuning time allow for easy operation on the field. Reduced dimensions allow space flexibility: 5HU, 19" rack can accommodate a single VHF filter, two single VHF filters or a single VHF and a single UHF filters. Customized control interfaces available.



Electrical Specifications

Frequency band:	118 - 156 MHz
Impedance:	50 Ω
Max Power:	200W CW
Interfaces:	Ethernet, RS485 or RS422

Mechanical Specifications

Connector Type:	N Female
Dimensions:	½ 19" rack, 5HU, depth. 695 mm
Operating temp.:	-10°C to +55°C
Tuning method:	Automatic, telescopic movement

Automatic Band Pass Filter	VSWR	Tuning time	Insertion Loss	Selectivity
FPBA210-V/1 F02VS210A10Sxxxx	< 1.6:1	Typ. 6 sec	< 1dB	> 14 dB @ ± 0.4%
FPBA210-V/1D F02VS210A20Sxxxx	< 1.6:1	Typ. 6 sec	< 1dB	> 14 dB @ ± 0.4%

Possible Configurations

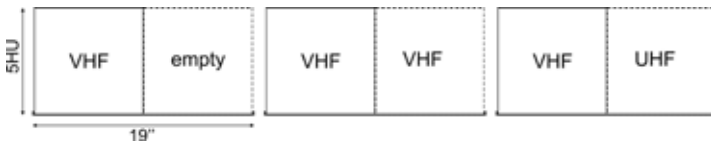

FPBA210-V/1
front view



FPBA210-V/1
rear view

Automatic Tuning Band Pass Filters VHF

210 double cavity window coupled

5 units window coupled double cavity automatic tuning filters are a key factor in emergencies. High selectivity, extended frequency range and fast tuning time allow for easy operation on the field. The independent tuning capability and accuracy offer optimum software controlled matching performance. Customized control interfaces available.



Electrical Specifications

Frequency band:	112 - 156 MHz
Impedance:	50 Ω
Max Power:	200W CW
Interfaces:	Ethernet, RS485 or RS422

Connector Type:	N Female
Dimensions:	19" rack, 5HU, depth. 690 mm
Operating temp.:	-10°C to +55°C
Tuning method:	Automatic, telescopic movement

Automatic Band Pass Filter	VSWR	Tuning time	Insertion Loss	Selectivity
FPBA210-V/2 F02ES210A1WDxxxx	< 1.6:1	Typ. 7 Sec.	< 2dB	> 30 dB @ ± 0.4%



FPBA210-V/2
front view



FPBA210-V/2
rear view



AUTOMATIC
TUNING
BAND PASS
FILTERS

UHF

Automatic Tuning Band Pass Filters UHF

210 single cavity

5 units single cavity automatic tuning filters are a key factor in emergencies. High selectivity, extended frequency range and fast tuning time allow for easy operation on the field. Reduced dimensions allow space flexibility: 5HU, 19" rack can accommodate a single UHF filter, two single UHF filters or a single UHF and a single VHF filters. Customized control interfaces available.



Electrical Specifications

Frequency band:	225 - 400 MHz
Impedance:	50 Ω
Max Power:	200W CW
Interfaces:	Ethernet, RS485 or RS422

Mechanical Specifications

Connector Type:	N Female
Dimensions:	½ 19" rack, 5HU, depth. 640 mm
Operating temp.:	-10°C to +55°C
Tuning method:	Automatic, telescopic movement

Automatic Band Pass Filter	VSWR	Tuning time	Insertion Loss	Selectivity
FPBA210-U/1 F02US210A10Sxxxx	< 1.6:1	Typ. 10 sec	< 1dB	> 15 dB @ $\pm 0.4\%$ > 17 dB @ $\pm 0.5\%$
FPBA210-U/1D F02US210A20Sxxxx	< 1.6:1	Typ. 10 sec	< 1dB	> 15 dB @ $\pm 0.4\%$ > 17 dB @ $\pm 0.5\%$

Possible Configurations

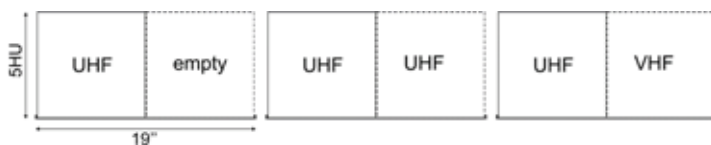

FPBA210-U/1
front view



FPBA210-U/1
rear view

Automatic Tuning Band Pass Filters UHF

210 double cavity window coupled

5 units window coupled double cavity automatic tuning filters are a key factor in emergencies. High selectivity, extended frequency range and fast tuning time allow for easy operation on the field. The independent tuning capability and accuracy offer optimum software controlled matching performance. Customized control interfaces available.



Electrical Specifications

Frequency band:	225 - 400 MHz
Impedance:	50 Ω
Max Power:	200W CW
Interfaces:	Ethernet, RS485 or RS422

Mechanical Specifications

Connector Type:	N Female
Dimensions:	19" rack, 5HU, depth. 623 mm
Operating temp.:	-10°C to +55°C
Tuning method:	Automatic, telescopic movement

Automatic Band Pass Filter	VSWR	Tuning time	Insertion Loss	Selectivity
FPBA210-U/2 F02US210A1WDxxxx	< 1.6:1	Typ. 10 Sec.	< 2dB	> 30 dB @ ± 0.4%



FPBA210-U/2
front view



FPBA210-U/2
rear view



AUTOMATIC
TUNING
COMBINERS
VHF

Automatic Tuning Combiner VHF

STAR 210 double cavity

Combiners allow several radio channels to operate at one site sharing a common antenna. Automatic tuning combiners are a key factor in emergencies, as channels can be changed very quickly from remote. High selectivity, extended frequency range and fast tuning time allow for easy operation on the field. Customized control interfaces available.

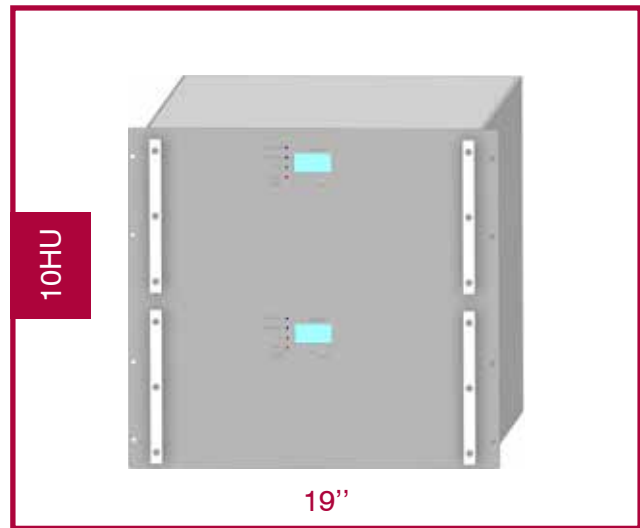

Electrical Specifications

Frequency band:	112 - 156 MHz
Impedance:	50 Ω
Max Power:	200W CW
Interfaces:	Ethernet, RS485 or RS422

Connector Type:	N Female
Dimensions:	19" rack, 10HU, depth. 690 mm
Operating temp.:	-10°C to +55°C
Tuning method:	Automatic, telescopic movement

Automatic Combiner	VSWR	Tuning time	Insertion Loss	Selectivity
MCPSA210-V/2 F06ES210A2SDxxxx	< 1.6:1	Typ. 7 Sec.	< 2dB	> 30 dB @ \pm 0.4%

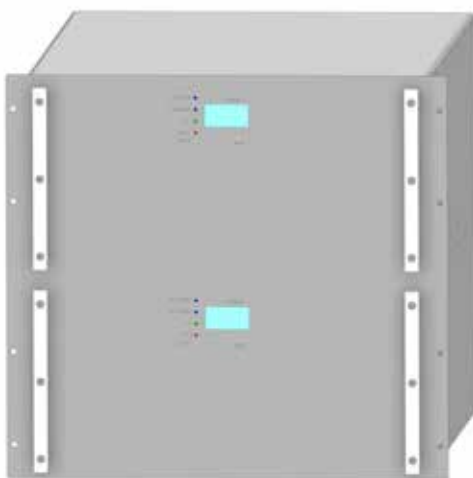

MCPSA210-V/2
front view



MCPSA210-V/2
rear view





www.telmecc.net

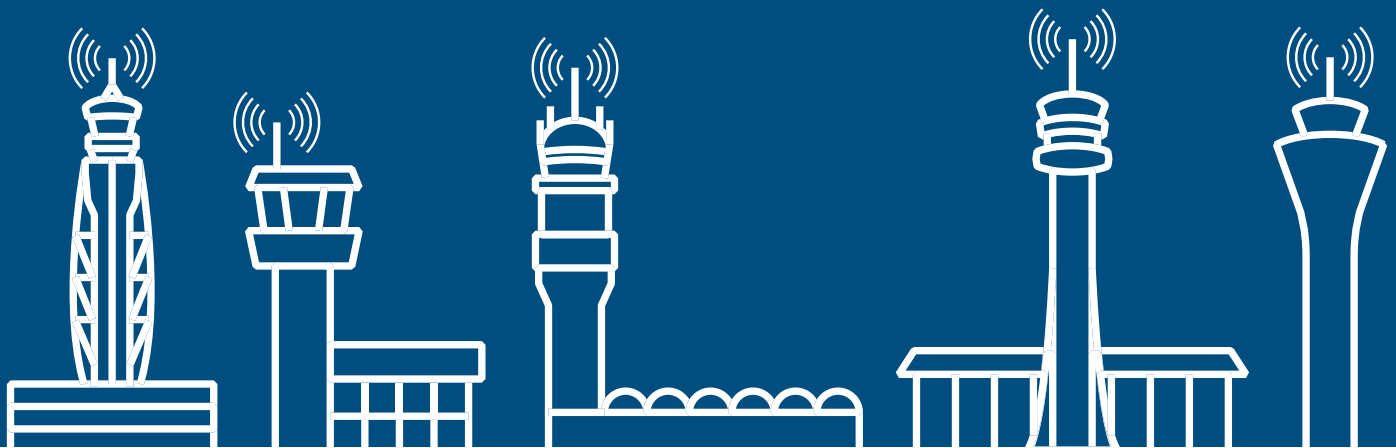

Telmecc
RADIO FREQUENCY FILTERING SYSTEMS

SINCE 1975 - MADE IN ITALY

Telmecc Coop S.c.a.r.l.

Via A. Meucci, 8 - 50012 Grassina (Florence) - ITALY
Tel +39 055 644071/644087 - Fax +39 055 641485
e-mail: info@telmecc.net - www.telmecc.net